

Non-Metallic Hose Assemblies for CANDU Nuclear Power Plants



Thorburn Flex Inc.

173 Oneida Dr.,
Pointe-Claire, Quebec,
Canada H9R 1A9

Tel: 514-695-8710
Fax: 514-695-1321
sales@thorburnflex.com



Thorburn Flex Inc offers unmatched capabilities and expertise in applications engineering, design development and manufacture of non metallic and metallic flexible piping systems for Candu nuclear power plants. Operating under a strategy of global presence Thorburn has structured and developed a specific Candu business unit used to service this niche market sector. Through this Candu business unit Thorburn’ nuclear components consistently meet and exceed all the quality design requirements of our Candu nuclear reactor business partners.

Verifications testing

Thorburn’s testing laboratory provides high and low temperature, impulse, vibration, pressure, “EQ” environmental impact testing specified to customer, N285 or other contract requirements

Full traceability

Thorburn material control laboratory provides full material traceability

Fitting to end joint technology

Industry leading techniques for end connector and joint assemblies

Commitment to R & D

Thorburn’s continuously achieves the state of the art in fluid transfer technology through innovation in engineering, materials, manufacturing and quality



LOW PRESSURE HOSES

Model NLOL	
Reinforced Low Pressure Elastomeric Hose.....	2
Push-on/lock-in Reusable Coupling System.....	3

MEDIUM PRESSURE HOSES

Model NC5R	
Reinforced Medium Pressure Elastomer Hose.....	4
Sure-Grip Reusable Coupling System.....	5

HIGH PRESSURE HOSES

Model NC2AH	
Reinforced High Pressure Elastomer Hose.....	6
Sure-Grip Reusable Coupling System.....	7
Model NC2AEH	
Reinforced High Pressure Elastomer Hose.....	8
Sure-Grip Reusable Coupling System.....	9
Model M2	
High Pressure Mighty-Crimp Coupling System.....	10

VERY HIGH PRESSURE HOSES

Model NC12	
Reinforced Very High Pressure Elastomeric Hose.....	12
Mighty-Crimp Series M4.....	13
Model NC13	
Reinforced Very High Pressure Elastomeric Hose.....	14
Mighty-Crimp Series M5.....	15
Model NC15	
Reinforced Very High Pressure Elastomeric Hose.....	16
Mighty-Crimp Series M6.....	17

MULTI-PURPOSE HOSE

Model N16TA	
Multi-Purpose Transfer Hose.....	18

STEAM HOSE

Model N30TS	
Steam Transfer Hose.....	19

AIR/WATER/STEAM COUPLINGS & CLAMPS

Model N16TA/N30TS	
Ground Joint Heavy Duty Couplings & Clamps.....	20

ULTRA HIGH PRESSURE HOSE

Model N23TWX	
Water Blast Hose Assemblies.....	23
Model N44TW	
Water Blast Hose Assemblies.....	24

QUICK COUPLINGS

Series NQCH	
Quick Disconnect Couplings.....	25
Series N71	
Flush Face/Dry Break Couplings.....	27
Series NT72	
Double Shut-Off Valve Couplings.....	28
Series NT82	
Flush Straight-Through Couplings.....	29
Series NT800	
Heavy Duty Hydraulic Rebuildable Live Swivels.....	30
Series NTFD69	
High Pressure Water Blast couplings.....	31
Series NT85	
High Pressure Thread to Connect Couplings.....	32
Series Omega	
Dry Break Ball Valve Couplings.....	33

TECHNICAL DATA

Hose Assembly Instructions.....	36
Field Assembly Instructions.....	37
Service Life Factors.....	38
Ordering Information.....	39

Model NLOL

Reinforced Low Pressure Elastomeric Hose

Simply Push-On/ Lock-In



APPLICATIONS

Control valve plumb up, flexible connector between instrument and instrument air supply, shop air systems. Recommended for low pressure transfer of gasoline, fuel and lubricating oils, air and water. Not recommended for hydraulic impulse applications.

Thorburn's "Push-On/Lock-In" is registered for systems that require B31.1 components. This unique hose and coupling system is an excellent economical field or prefactory assembled flexible connector. It minimizes stress on an instrumentation tubing system through vibration isolation and simplifies misalignment compensation. It also permits the use of Thorburn Push-On/Lock-In couplings, to which no ferrules or clamps are required. Push-on/Lock-In elastomers have a radiation resistance of 6×10^7 Roentgens.

CONSTRUCTION

Tube: Type C black Nitrile-Butadiene blend synthetic oil resistant.

Reinforcement: One polyester textile braid applied through a special braiding process for lock-on characteristics.

Cover: Black type C (Nitrile-Butadiene). Colours type A chloroprene synthetic rubber oil abrasion and ozone resistant.

Temperature: -40°F (40°C) to 212°F (100°C). Air and water 100°F (70°C).

Couplings: Thorburn's Push-On/Lock-In found on page 3.

Hose compatibility: Aeroquip 2556/2565, 2575/1525.

Simple: Push-On/Lock-In!



No clamps!

Thorburn Part Number	Hose I.D.		Hose O.D.		Design Pressure		Min. Bursts		Minimum Bend		Weight		Vacuum	
	in.	mm	in.	mm	PSI	MPa	PSI	MPa	in.	mm	lbs/100ft	kg/100m	in./Hg	mm/Hg
N4LOL*	1/4	6.3	0.47	12	200	1.38	800	5.52	3	76.2	8	12	28	710
N6LOL*	3/8	10	0.61	15	200	1.38	800	5.52	3	76.2	11	16	28	710
N8LOL*	1/2	12.5	0.75	19	200	1.38	800	5.52	5	127.0	15	22	28	710
N12LOL*	3/4	19	1.04	26	200	1.03	600	5.52	7	177.8	24	36	18	457

* = Material code (Black Standard no code. For color codes, i.e. Grey Part Number: N4LOLGY)

AVAILABLE COLOURS: Standard: Black; Option: Grey (GY), Blue (BE), Green (GR), Red (RD) and Yellow (YW).

SPECIAL NOTE: Nominal hose & coupling sizes listed in 1/16"; i.e. 12 = 3/4", 6 = 3/8", etc.

HOW TO ORDER THORBURN NLOL HOSE ASSEMBLIES

Size Hose	1st End Size/Coupling	1st End Material	2nd End Size/Coupling	2nd End Material	Length inches
N8LOLBE	8RFTA	S6	8RMPB	6C	018

For a 1/2" blue Push-On/Lock-In hose c/w 1/2" O.D., 316SS tube connector, other 316SS 1/2" male NPT.

Push-On/Lock-In NLOL Reusable Coupling System

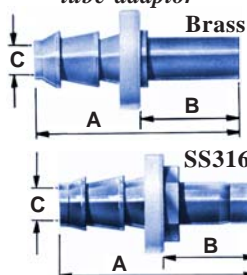
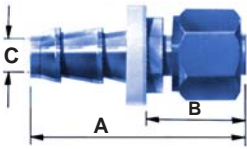
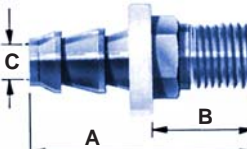
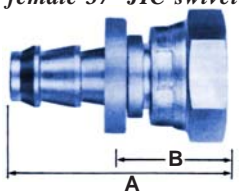
<p><i>Push-On/Lock-In to tube adaptor</i></p> 	Thorburn Part Number		Hose I.D.	Tube O.D.	A	B	C	
	Brass	Stainless 316	in.	in.	in.	in.	in.	
	N4LOL-4RFTB	N4LOL-4RFTS6	1/4	1/4	1.68	0.92	0.188	
	N4LOL-6RFTB	N4LOL-6RFTS6	1/4	3/8	1.89	0.98	0.188	
	N6LOL-4RFTB	N6LOL-4RFTS6	3/8	1/4	1.89	0.98	0.297	
	N6LOL-6RFTB	N6LOL-6RFTS6	3/8	3/8	1.89	0.98	0.297	
	N8LOL-8RFTB	N8LOL-8RFTS6	1/2	1/2	2.29	1.23	0.422	
N12LOL-12RFTB	N12LOL-12RFTS6	3/4	3/4	2.98	1.50	0.656		
Other sizes and materials available upon request								
<p><i>Push-On/Lock-In to Swagelok® compatible nut and ferrule</i></p> 	Thorburn Part Number		Hose I.D.	Tube O.D.	A	B	C	
	N4LOL-4RFTAB	N4LOL-4RFTAS6	1/4	1/4	1.68	0.92	0.188	
	N4LOL-6RFTAB	N4LOL-6RFTAS6	1/4	3/8	1.89	0.98	0.188	
	N6LOL-4RFTAB	N6LOL-4RFTAS6	3/8	1/4	1.89	0.98	0.297	
	N6LOL-6RFTAB	N6LOL-6RFTAS6	3/8	3/8	1.89	0.98	0.297	
	N8LOL-8RFTAB	N8LOL-8RFTAS6	1/2	1/2	2.29	1.23	0.422	
	N12LOL-12RFTAB	N12LOL-12RFTAS6	3/4	3/4	2.98	1.50	0.656	
Swagelok compatible nuts and ferrules will mate with Parker CPI®, A-Lok®, Swagelok®, Bilok®, Gyrolok®, Instrumentation Tube Fittings								
<p><i>Push-On/Lock-In to male NPT</i></p> 	Thorburn Part Number		Hose I.D.	Thread	A	B	C	
	Brass	Stainless 316	in.	in.	in.	in.	in.	
	N4LOL-2RMPB	N4LOL-2RMPS6	1/4	1/8 - 27	1.46	0.66	0.188	
	N4LOL-4RMPB	N4LOL-4RMPS6	1/4	1/4 - 18	1.78	0.84	0.188	
	N4LOL-6RMPB	N4LOL-6RMPS6	1/4	3/8 - 18	1.78	0.88	0.188	
	N6LOL-4RMPB	N6LOL-4RMPS6	3/8	1/4 - 18	1.69	0.85	0.297	
	N6LOL-6RMPB	N6LOL-6RMPS6	3/8	3/8 - 18	1.78	0.88	0.297	
	N6LOL-8RMPB	N6LOL-8RMPS6	3/8	1/2 - 14	1.93	0.88	0.297	
	N8LOL-6RMPB	N8LOL-6RMPS6	1/2	3/8 - 18	2.03	0.91	0.422	
	N8LOL-8RMPB	N8LOL-8RMPS6	1/2	1/2 - 14	2.18	1.14	0.422	
N12LOL-12RMPB	N12LOL-12RMPS6	3/4	3/4 - 14	2.31	1.27	0.656		
<p><i>Push-On/Lock-In to female 37° JIC swivel</i></p> 	Thorburn Part Number		Hose I.D.	Tube O.D.	Thread	A	B	C
	Brass	Stainless 316	in.	in.	in.	in.	in.	in.
	N4LOL-4RFJXB	N4LOL-4RFJXS6	1/4	1/4	7/16 - 20	1.52	0.76	0.188
	N6LOL-6RFJXB	N6LOL-6RFJXS6	3/8	3/8	9/16 - 18	1.75	0.85	0.297
	N8LOL-8RFJXB	N8LOL-8RFJXS6	1/2	1/2	3/4 - 16	2.01	0.96	0.422
	N12LOL-12RFJXB	N12LOL-12RFJXS6	3/4	3/4	1-1/16 - 14	2.65	1.19	0.650



HOW TO ORDER COUPLINGS

AVAILABLE MATERIALS

Material	ASME	Codes
SS316	SA479	S6
Brass	B21/B16	B

Model NC5R

Reinforced Medium Pressure Elastomeric Hose



APPLICATIONS

Recommended for medium pressure hydraulic oil, fuel, lubricating oil, recirculating heavy water and air lines. Meets the requirements of SAE100R5. Thorburn's NC5R hose assembly can meet the requirements of ASME Section III, Section VIII and ANSI B31.1, when installed with Thorburn's Sure-Grip reusable coupling system. Radiation resistance of elastomer materials 6×10^7 Roentgens. Impulse cycles tested at 150,000 at 125% of design pressure for 7/8 in. I.D. and smaller and at 100,000 cycles at 100% of design pressure for 1-1/8 in. I.D. and larger.

CONSTRUCTION

Tube: Type C black Nitrile-Butadiene blend, oil resistant synthetic rubber.

Reinforcement: Single high tensile steel wire braid with one calendered polyester textile braid.

Cover: Type A black chloroprene blend. Oil, abrasion and ozone resistant synthetic rubber.

Temperature: -40°F (-40°C) to 212°F (100°C). Air service only maximum 250 psi (1.7 MPa) at 160°F (71°C).

Couplings: Thorburn Sure-Grip found on page 5.

Hose compatibility: Aeroquip 2651, 1503.

Thorburn Hose Part Number	Hose I.D.		Hose O.D.		Design Pressure		Min. Burst		Min. Bend		Weight	
	mm	in.	mm	in.	MPa	PSI	MPa	PSI	mm	in.	kg/ 100 m	lbs/ 100 ft
N4C5R	5	3/16	13.2	0.52	20.7	3000	82.7	12000	76.2	3	22	15
N5C5R	6.3	1/4	14.8	0.58	20.7	3000	82.7	12000	85.9	3.4	27	18
N6C5R	8	5/16	17.2	0.67	15.5	2250	62.1	9000	101.6	4	36	24
N8C5R	11	13/32	19.5	0.77	13.8	2000	55.2	8000	117.1	4.6	42	28
N10C5R	12.5	1/2	23.4	0.92	12.1	1750	48.3	7000	139.7	5.5	58	39
N12C5R	16	5/8	27.7	1.08	10.3	1500	41.4	6000	165.1	6.5	73	49
N16C5R	22	7/8	31.2	1.23	5.5	800	22.1	3200	187.5	7.4	70	47
N20C5R	28	1-1/8	38.1	1.5	4.3	625	17.2	2500	228.6	9	87.9	59
N24C5R	35	1-3/8	45	1.75	3.5	500	13.8	2000	266.7	10.5	98.3	66
N32C5R	46	1-13/16	56.4	2.22	2.4	350	9.7	1400	336.6	13.3	134	90

HOW TO ORDER THORBURN NC5R HOSE ASSEMBLIES

Size Hose	1st End Size/Coupling	1st End Material	2nd End Size/Coupling	2nd End Material	Length inches	Nuclear Class 1, 2, 3
N12C5R	12RMP	S6	12RFJX	6C	144	Class 3

Special note:
For Class 6; B31.1; B31.3
leave Class Code blank

ASSEMBLY DESCRIPTION

3/4" ID N12C5R c/w 3/4" male NPT sure grip reusable coupling in 316SS material, other end 3/4" female 37° swivel in 316SS nipple socket steel nickel plated 144" O.A.L., Class 3.

Notes

- (1) All standard parts in stainless steel (304 or 316); insert threads plated with silver. (No Plating, put suffix "NP" after S4, S6, i.e. S4NP, S6NP)
- (2) Wetted parts (nipple) 316SS. Non-wetted parts (socket) carbon steel nickel plated.
- (3) Other carbon steel materials i.e. SA695, SA696, SA739.
- (4) Material not plated, add NP as suffix to Codes S4 and S6; i.e. S4NP, S6NP)
- (5) Carbon Steel/ Nickel Plated

Available Coupling Materials

Material	ASME	Codes
SS304 ⁽¹⁾	SA479	S4
SS316 ⁽¹⁾	SA479	S6
SS316/Steel	SA479/A108 ⁽³⁾	6C ⁽²⁾
Carbon Steel / Nickel plated	A108 ⁽³⁾	CN ⁽⁵⁾
—	—	NP ⁽⁴⁾

Sure-Grip NC5R Reusable Coupling System

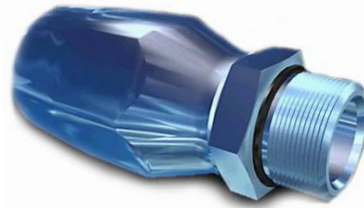

MALE PIPE NC5R-MP

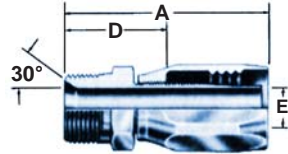

Thorburn Part Number	Hose Size	Thread	A	D	E \varnothing
N4C5R-4RMP*	3/16	1/4 - 18	1.86	1.11	0.13
N6C5R-6RMP*	5/16	3/8 - 18	2.13	1.23	0.24
N8C5R-6RMP*	13/32	3/8 - 18	2.48	1.33	0.39
N8C5R-8RMP*	13/32	1/2 - 14	2.73	1.58	0.36
N10C5R-12RMP*	1/2	3/4 - 14	2.94	1.65	0.48
N12C5R-12RMP*	5/8	3/4 - 14	3.24	1.67	0.55
N16C5R-12RMP*	7/8	3/4 - 14	2.80	1.53	0.82
N16C5R-16RMP*	7/8	1 - 11-1/2	2.99	1.72	0.82
N20C5R-20RMP*	1-1/8	1-1/4 - 11-1/2	3.23	1.87	1.05
N24C5R-24RMP*	1-3/8	1-1/2 - 11-1/2	3.48	2.03	1.28
N32C5R-32RMP*	1-13/16	2 - 11-1/2	4.05	2.20	1.75

* = Insert material code (see page 4).

FEMALE 37° (JIC) SWIVEL NC5R-RFJX

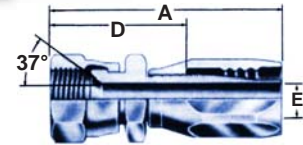

Thorburn Part Number	Hose Size	Thread	A	D	E \varnothing
N4C5R-4RFJX*	3/16	7/16 - 20	1.97	1.23	0.13
N6C5R-6RFJX*	5/16	9/16 - 18	2.33	1.43	0.24
N8C5R-8RFJX*	13/32	3/4 - 16	2.78	1.62	0.36
N12C5R-12RFJX*	5/8	1-1/16 - 12	3.49	1.92	0.55
N16C5R-16RFJX*	7/8	1-5/16 - 12	3.19	1.93	0.82
N20C5R-20RFJX*	1-1/8	1-5/8 - 12	3.43	2.07	1.05
N24C5R-24RFJX*	1-3/8	1-7/8 - 12	3.68	2.22	1.28
N32C5R-32RFJX*	1-13/16	2-1/2 - 12	4.39	2.55	1.75

* = Insert material code (see page 4).

MALE O-RING NC5R-RMB

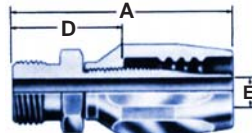

Thorburn Part Number	Hose Size	Thread	A	D	E \varnothing
N4C5R-4RMB*	3/16	7/16 - 20	1.68	0.94	0.17
N6C5R-6RMB*	5/16	9/16 - 18	1.95	1.05	0.24
N8C5R-8RMB*	13/32	3/4 - 16	2.35	1.20	0.36
N12C5R-12RMB*	5/8	1-1/16 - 12	3.10	1.53	0.55
N16C5R-16RMB*	7/8	1-5/16 - 12	2.99	1.72	0.82

* = Insert material code (see page 4).

MALE FLARE 37° JIC NC5R-RMJ

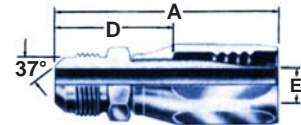

Thorburn Part Number	Hose Size	Thread	A	D	E \varnothing
N4C5R-4RMJ*	3/16	7/16 - 20	1.85	1.10	0.13
N6C5R-6RMJ*	5/16	9/16 - 18	2.12	1.22	0.24
N8C5R-8RMJ*	13/32	3/4 - 16	2.57	1.42	0.36
N12C5R-12RMJ*	5/8	1-1/16 - 12	3.35	1.78	0.55
N16C5R-16RMJ*	7/8	1-5/16 - 12	2.96	1.69	0.82
N20C5R-20RMJ*	1-1/8	1-5/8 - 12	3.22	1.86	1.05
N24C5R-24RMJ*	1-3/8	1-7/8 - 12	3.44	1.99	1.28
N32C5R-32RMJ*	1-13/16	2-1/2 - 12	4.22	2.38	1.75

* = Insert material code (see page 4).

90° ELBOW
NC5R-RFJX90S (short)
NC5R-RFJX90L (long)

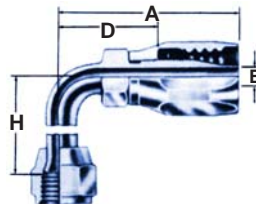

Thorburn Part Number	Hose Size	Thread	A	D	E \varnothing	H
N4C5R-4RFJX90S*	3/16	7/16 - 20	1.74	0.99	0.13	0.68
N4C5R-4RFJX90L*	3/16	7/16 - 20	1.74	0.99	0.13	1.80
N6C5R-6RFJX90S*	5/16	9/16 - 18	2.13	1.23	0.24	0.85
N6C5R-6RFJX90L*	5/16	9/16 - 18	2.13	1.23	0.24	2.18
N8C5R-8RFJX90S*	13/32	3/4 - 16	2.76	1.61	0.36	1.09
N8C5R-8RFJX90L*	13/32	3/4 - 16	2.88	1.73	0.36	2.43
N12C5R-12RFJX90S*	5/8	1-1/16 - 12	3.74	2.17	0.55	1.82
N12C5R-12RFJX90L*	5/8	1-1/16 - 12	3.74	2.17	0.55	3.73
N16C5R-16RFJX90S*	7/8	1-5/16 - 12	3.55	2.28	0.82	2.39
N16C5R-16RFJX90L*	7/8	1-5/16 - 12	3.55	2.28	0.82	4.58

* = Insert material code (see page 4).

HOW TO ORDER COUPLINGS ONLY

Part Number Basic	Material See codes page 4
N4C5R-4RMJ	S6

Description: 1/4" hose end for N4C5R hose with 7/16 - 20 male flare 37° JIC thread in 316SS material.

To order: Insert Stems only i.e., N4C5R-4R-I-FJX-S6NP⁽²⁾
Sockets only i.e., N4C5R-4R-SK-CN⁽²⁾-Class 3⁽¹⁾

*Insert Material Code (for details see page 4).

⁽¹⁾ If applicable, insert suffix Class (1, 2 or 3)

Special note: For Class 6; B31.1; B31.3, leave Code Class blank i.e., N4C5R-4R-SK-CN⁽²⁾

I= Reusable insert stems SK= Reusable socket

⁽²⁾ Material Code (for details see page 4)

Model NC2AH

Reinforced High Pressure Elastomer Hose



CONSTRUCTION

Tube: Type C Nitrile(Buna N), oil resistant synthetic rubber. Black color

Reinforcement: Two braids of high tensile steel wire.

Cover: Neoprene synthetic rubber oil, ozone and extremely abrasive resistant. Black color

Temperature: -40°F (-40°C) to 212°F (100°C) constant intermittent (up to 10% of operating time 300°F (149°C)).

Couplings: Thorburn's reusable Sure-Grip found on page 7 and Mighty-Crimp on page 11.

Hose compatibility: Non-skive Aeroquip FC212. Skive type: CR114, 1529, 2781 (Thorburn NC2AH rubber cover must be skived for fitting to end joint compatibility with Aeroquip.

APPLICATIONS

Recommended for high pressure high impulse applications, transferring hydraulic oil, fuel, lubricating oil, recirculating heavy water, air lines. Typically used as the flex connector between F/M Ram portion and the cradle portion of the F/M fluid system D₂O and oil hydraulic lines.

Thorburn's Model NC2AH meets and/or exceeds the requirements of SAE 100R2. Thorburn's NC2AH hose assembly can meet the requirements of ASME Section III, CSAN285.2, ASME Section VIII and ANSI B31.1 when installed with Thorburn's Sure-Grip reusable or Mighty-Crimp coupling systems.

Thorburn's NC2AH hose is radiation resistant and its elastomeric material is 6 x 10⁶ Roentgens. Impulse tested at 133% of design pressure for 200,000 cycles.

Thorburn Hose Part Number	Hose I.D.		Hose O.D.		Design Pressure		Min. Burst		Min. Bend		Weight	
	mm	in.	mm	in.	MPa	psi	MPa	psi	mm	in.	kg/100 m	lbs/100 ft
N4C2AH	6.4	1/4	14.4	0.59	34.5	5000	138	20000	101.6	4.0	37	25
N6C2AH	9.5	3/8	18.8	0.74	27.6	4000	110	16000	127.0	5.0	54	36
N8C2AH	12.7	1/2	22.3	0.88	24.1	3500	97	14000	177.8	7.0	66	44
N12C2AH	19.0	3/4	28.7	1.13	18.6	2700	76	11000	241.3	9.5	89	60
N16C2AH	25.4	1	37.0	1.46	17.9	2600	72	10400	304.8	12.0	128	80
N20C2AH	32.0	1-1/4	47.5	1.87	11.2	1625	44.8	6500	419.1	16.5	216	145
N24C2AH	38.0	1-1/2	54.6	2.15	8.6	1250	34.5	5000	508.0	20.0	245	164
N32C2AH	51.0	2	67.3	2.65	7.8	1125	33.1	4800	635.0	25.0	300	205
(4) N48C2AH	76.0	3	103.5	4.14	6.1	900	24.8	3600	762.0	30.0	500	333

(4) Special coupling system is required, contact Thorburn with your applications.

SPECIAL NOTE: Nominal hose & coupling sizes listed in 1/16"; i.e. 12 = 3/4", 6 = 3/8", etc.

HOW TO ORDER THORBURN NC2AH HOSE ASSEMBLIES

Size Hose	1st End Size/Coupling	1st End Material	2nd End Size/Coupling	2nd End Material	Length inches	Nuclear Class 1, 2, 3
N12C2AH	12RFJX	S6	12RMB	6C	057	Class 3

Special note:
For Class 6; B31.1; B31.3
leave Class Code blank

ASSEMBLY DESCRIPTION

3/4" ID N12C2AH c/w Sure-Grip 3/4" female 37° swivel, nipple 316, socket steel nickel plated, other end Sure-Grip 3/4" male NPT, nipple 316, socket steel nickel plated, 57" O.A.L. Class 3.

Notes

- (1) All standard parts in stainless steel (304 or 316); insert threads plated with silver. (No Plating, put suffix "NP" after S4, S6, i.e. S4NP, S6NP)
- (2) Wetted parts (nipple) 316SS. Non-wetted parts (socket) carbon steel nickel plated.
- (3) Other carbon steel materials i.e. SA695, SA696, SA739.
- (4) Material not plated, add NP as suffix to Codes S4 and S6; i.e. S4NP, S6NP)
- (5) Carbon Steel/ Nickel Plated

Available Coupling Materials

Material	ASME	Codes
SS304 ⁽¹⁾	SA479	S4
SS316 ⁽¹⁾	SA479	S6
SS316/Steel	SA479/A108 ⁽³⁾	6C ⁽²⁾
Carbon Steel / Nickel plated	A108 ⁽³⁾	CN ⁽⁵⁾
—	—	NP ⁽⁴⁾

Model NC2AH

Sure-Grip Reusable Coupling System

Thorburn Part Number	Hose I.D.	Thread	A	D	E ϕ	H	
N4C2AH-4RMP*	1/4	1/4 - 18	2.50	1.26	0.17		<p>NC2AH-RMP Male pipe</p>
N6C2AH-6RMP*	3/8	3/8 - 18	2.75	1.28	0.31		
N8C2AH-6RMP*	1/2	3/8 - 18	2.84	1.32	0.39		
N8C2AH-8RMP*	1/2	1/2 - 14	3.09	1.58	0.39		
N12C2AH-12RMP*	3/4	3/4 - 14	3.61	1.74	0.61		
N16C2AH-16RMP*	1	1 - 11-1/2	4.40	2.36	0.82		
N20C2AH-20RMP*	1-1/4	1-1/4 - 11-1/2	4.90	2.59	1.05		
N24C2AH-24RMP*	1-1/2	1-1/2 - 11-1/2	4.98	2.74	1.28		
N32C2AH-32RMP*	2	2 - 11-1/2	5.50	3.05	1.75		
N4C2AH-4RMJ*	1/4	7/16 - 20	2.49	1.25	0.17		<p>NC2AH-RMJ Male 37° (JIC) flare</p>
N6C2AH-6RMJ*	3/8	9/16 - 18	2.75	1.28	0.30		
N8C2AH-8RMJ*	1/2	3/4 - 16	2.99	1.48	0.39		
N12C2AH-12RMJ*	3/4	1-1/16 - 12	3.72	1.85	0.61	NFA2-3003.7	
N16C2AH-16RMJ*	1	1-5/16	4.38	2.33	0.82		
N20C2AH-20RMJ*	1-1/4	1-5/8 - 12	4.89	2.58	1.05		
N24C2AH-24RMJ*	1-1/2	1-7/8 - 12	5.06	2.82	1.28		
N4C2AH-4RMB*	1/4	7/16 - 20	2.22	1.30	0.17		<p>NC2AH-RMB Male "O" ring boss</p>
N6C2AH-6RMB*	3/8	9/16 - 18	2.45	1.37	0.31		
N8C2AH-8RMB*	1/2	3/4 - 16	2.71	1.20	0.39		
N12C2AH-12RMB*	3/4	1-1/16 - 12	3.46	1.59	0.61	NFA2-3003.7	
N16C2AH-16RMB*	1	1-5/16 - 12	3.93	1.87	0.82		
N20C2AH-20RMB*	1-1/4	1-5/8 - 12	4.40	2.07	1.05		
N24C2AH-24RMB*	1-1/2	1-7/8 - 12	4.31	2.07	1.28		
N4C2AH-4RFJX*	1/4	7/16 - 20	2.64	1.41	0.17		<p>NC2AH-RFJX female 37° (JIC) swivel</p>
N6C2AH-6RFJX*	3/8	9/16 - 18	2.98	1.51	0.26	NFA2-3003.7	
N8C2AH-8RFJX*	1/2	3/4 - 16	3.20	1.68	0.39	NFA2-3003.7	
N12C2AH-12RFJX*	3/4	1-1/16 - 12	3.86	1.99	0.61	NFD3-3514.5	
N16C2AH-16RFJX*	1	1-5/16 - 12	4.48	2.43	0.82	NFH-3.3471.5	
N20C2AH-20RFJX*	1-1/4	1-5/8 - 12	5.10	2.78	1.05		
N24C2AH-24RFJX*	1-1/2	1-7/8 - 12	5.16	2.93	1.28		
N32C2AH-32RFJX*	2	2-1/2 - 12	5.90	3.47	1.75		
N4C2AH-4RFJX90S*	1/4	7/16 - 20	2.40	1.17		0.68	<p>NC2AH-RFJX90S (short) NC2AH-RFJX90L (long)</p>
N4C2AH-4RFJX90L*	1/4	7/16 - 20	2.40	1.17	0.17	1.80	
N6C2AH-6RFJX90S*	3/8	9/16 - 18	2.72	1.25		0.85	
N6C2AH-6RFJX90L*	3/8	9/16 - 18	2.72	1.25	0.31	2.18	
N8C2AH-8RFJX90S*	1/2	3/4 - 16	3.02	1.52		1.09	
N8C2AH-8RFJX90L*	1/2	3/4 - 16	3.15	1.64	0.39	2.43	
N12C2AH-12RFJX90S*	3/4	1-1/16 - 12	4.11	2.24		1.82	
N12C2AH-12RFJX90L*	3/4	1-1/16 - 12	4.11	2.24	0.61	3.73	
N16C2AH-16RFJX90S*	1	1-5/16 - 12	4.84	2.79	0.82	2.39	
N16C2AH-16RFJX90L*	1	1-5/16 - 12	4.84	2.78	0.82	4.58	
N4C2AH-4RFFX*	1/4	9/16 - 18	2.75	1.52	0.17		<p>NC2AH-RFFX flat face "O" ring swivel "T" Thread</p>
N6C2AH-6RFFX*	3/8	11/16 - 16	3.02	1.55	0.26		
N8C2AH-8RFFX*	1/2	13/16 - 16	3.40	1.89	0.39		
N12C2AH-12RFFX*	3/4	1-3/16 - 12	4.05	2.18	0.61		
N16C2AH-16RFFX*	1	1-7/16 - 12	4.78	2.73	0.82		

To order: Insert Stems only i.e., N4C2AH-4R-I-FJX-S6NP⁽²⁾-Class 3⁽¹⁾
Sockets only i.e., N4C2AH-4R-SK-CN⁽²⁾-Class 3⁽¹⁾

*Insert Material Code (for details see page 6).

⁽¹⁾ If applicable, insert suffix Class (1, 2 or 3)

Special note: For Class 6; B31.1; B31.3, leave Code Class blank i.e., N4C2AH-4R-SK-CN⁽²⁾

I= Reusable insert stems SK= Reusable socket

⁽²⁾ Material Code (for details see page 6)

Model NC2AEH Reinforced High Pressure Elastomer Hose



CONSTRUCTION

Tube: Type C black EPDM EPR (ethylene-propylenediene-terpolymer) synthetic rubber blend.

Reinforcement: Two braids of high tensile steel wire.

Cover: Bright yellow for identification hypalon (chloro-sulfonyl polyethylene) blend, extremely abrasion and ozone resistant.

Temperature: -40°F (-40°C) to 212°F (100°C).

Couplings: Thorburn's reusable Sure-Grip found on page 9 and factory assembled Mighty-Crimp on page 11.

Hose compatibility: Aeroquip CR266, CR166.

APPLICATIONS

Thorburn's NC2AEH, recommended for high pressure, high impulse, was specifically designed to be the flexible joint system to transfer heavy water (D₂O) from the actuator supply lines; magazine and Ram D₂O supply line; magazine return line found in a fueling machine catenary system of a Candu PHW nuclear generating station.

Thorburn's NC2AEH meets and/or exceeds the requirements of SAE 100R2A. Thorburn's NC2AEH hose assembly can meet the requirements of ASME Section III, CSA N285.2, ASME Section VIII and ANSI B31.1 when installed with Thorburn's Sure-Grip reusable or Mighty-Crimp coupling systems. Thorburn's NC2AEH is impulse tested at 50,000 cycles at 133% of design pressure and its elastomeric materials are radiation resistant to 3 x 10⁸ Roentgens.

Thorburn Hose Part Number	Hose I.D.		Hose O.D.		Design Pressure		Min. Burst		Min. Bend		Weight	
	mm	in.	mm	in.	MPa	PSI	MPa	PSI	mm	in.	kg/ 100 m	lbs/ 100 ft
N4C2AEH	6.	1/4	17.5	0.69	34.5	5000	138	20000	1	4	4	32
N6C2AEH	9.5	3/8	21.4	0.84	27.6	4000	110	16000	1	5	67	45
N8C2AEH	12.7	1/2	24.6	0.97	24.1	3500	97	14000	17	7	8	54
N12C2AEH	19.0	3/4	31.8	1.25	18.6	2700	76	11000	237	9.5	115.5	77
N16C2AEH	25.4	1	39.7	1.56	17.9	2600	72	10400	300	12	162	108

HOW TO ORDER THORBURN NC2AEH HOSE ASSEMBLIES

Size Hose	1st End Size/Coupling	1st End Material	2nd End Size/Coupling	2nd End Material	Length inches	Nuclear Class 1, 2, 3
N12C2AEH	12RMB	6C	12RFJX	6C	480	Class 3

SPECIAL NOTE: Nominal hose & coupling sizes listed in 1/16"; i.e. 12 = 3/4", 6 = 3/8", etc.

Special note:
For Class 6; B31.1; B31.3
leave Code Class blank

ASSEMBLY DESCRIPTION

3/4" hose type N12C2AEH c/w 3/4" Sure-Grip reusable male "O" ring boss coupling nipple in 316SS and socket in nickel plated steel, other end 3/4" Sure-Grip reusable female 37° (JIC swivel) coupling nipple in 316SS and socket in nickel plated steel 480" long Code Class 3.

Notes

- (1) All standard parts in stainless steel (304 or 316); insert threads plated with silver. (No Plating, put suffix "NP" after S4, S6, i.e. S4NP, S6NP)
- (2) Wetted parts (nipple) 316SS. Non-wetted parts (socket) carbon steel nickel plated.
- (3) Other carbon steel materials i.e. SA695, SA696, SA739.
- (4) Material not plated, add NP as suffix to Codes S4 and S6; i.e. S4NP, S6NP)
- (5) Carbon Steel/ Nickel Plated

Standard Coupling Materials & Codes

Material	ASME	Codes
SS304 ⁽¹⁾	SA479	S4
SS316 ⁽¹⁾	SA479	S6
SS316/Steel	SA479/A108 ⁽³⁾	6C ⁽²⁾
Carbon Steel/ Nickel plated	A108 ⁽³⁾	CN ⁽⁵⁾
—	—	NP ⁽⁴⁾

Model NC2AEH

Sure-Grip Reusable Coupling System

Thorburn Part Number	Hose I.D.	Thread	A	D	E ϕ	H	
N4C2AEH-4RMP*	1/4	1/4 - 18	2.50	1.26	0.17		<p><i>NC2AEH-RMP Male pipe</i></p>
N6C2AEH-6RMP*	3/8	3/8 - 18	2.75	1.28	0.31		
N8C2AEH-6RMP*	1/2	3/8 - 18	2.84	1.32	0.39		
N8C2AEH-8RMP*	1/2	1/2 - 14	3.09	1.58	0.39		
N12C2AEH-12RMP*	3/4	3/4 - 14	3.61	1.74	0.61		
N16C2AEH-16RMP*	1	1 - 11-1/2	4.40	2.36	0.82		
N4C2AEH-4RMJ*	1/4	7/16 - 20	2.49	1.25	0.17		<p><i>NC2AEH-RMJ Male 37° (JIC) flare</i></p> <p>Nuclear Class II registration NFA2-3003.7</p>
N6C2AEH-6RMJ*	3/8	9/16 - 18	2.75	1.28	0.30		
N8C2AEH-8RMJ*	1/2	3/4 - 16	2.99	1.48	0.39		
N12C2AEH-12RMJ*	3/4	1-1/16 - 12	3.72	1.85	0.61		
N16C2AEH-16RMJ*	1	1-5/16	4.38	2.33	0.82		
N4C2AEH-4RMB*	1/4	7/16 - 20	2.22	1.30	0.17		<p><i>NC2AEH-RMB Male "O" ring boss</i></p> <p>Nuclear Class II registration NFA2-3003.7</p>
N6C2AEH-6RMB*	3/8	9/16 - 18	2.45	1.37	0.31		
N8C2AEH-8RMB*	1/2	3/4 - 16	2.71	1.20	0.39		
N12C2AEH-12RMB*	3/4	1-1/16 - 12	3.46	1.59	0.61		
N16C2AEH-16RMB*	1	1-5/16 - 12	3.93	1.87	0.82		
N4C2AEH-4RFJX*	1/4	7/16 - 20	2.64	1.41	0.17		<p><i>NC2AEH-RFJX female 37° (JIC) swivel</i></p> <p>Nuclear Class II & III registration NFA2-3003.7 NFH-3.3471.5</p>
N6C2AEH-6RFJX*	3/8	9/16 - 18	2.98	1.51	0.26		
N8C2AEH-8RFJX*	1/2	3/4 - 16	3.20	1.68	0.39		
N12C2AEH-12RFJX*	3/4	1-1/16 - 12	3.86	1.99	0.61		
N16C2AEH-16RFJX*	1	1-5/16 - 12	4.48	2.43	0.82		
N4C2AEH-4RFJX90S*	1/4	7/16 - 20	2.40	1.17		0.68	<p><i>NC2AEH-RFJX90S (short)</i> <i>NC2AEH-RFJX90L (long)</i></p>
N4C2AEH-4RFJX90L*	1/4	7/16 - 20	2.40	1.17	0.17	1.80	
N6C2AEH-6RFJX90S*	3/8	9/16 - 18	2.72	1.25		0.85	
N6C2AEH-6RFJX90L*	3/8	9/16 - 18	2.72	1.25	0.31	2.18	
N8C2AEH-8RFJX90S*	1/2	3/4 - 16	3.02	1.52		1.09	
N8C2AEH-8RFJX90L*	1/2	3/4 - 16	3.15	1.64	0.39	2.43	
N12C2AEH-12RFJX90S*	3/4	1-1/16 - 12	4.11	2.24		1.82	
N12C2AEH-12RFJX90L*	3/4	1-1/16 - 12	4.11	2.24	0.61	3.73	
N16C2AEH-16RFJX90S*	1	1-5/16 - 12	4.84	2.79	0.82	2.39	
N16C2AEH-16RFJX90L*	1	1-5/16 - 12	4.84	2.78	0.82	4.58	
N4C2AEH-4RFFX*	1/4	9/16 - 18	2.75	1.52	0.17		
N6C2AEH-6RFFX*	3/8	11/16 - 16	3.02	1.55	0.26		
N8C2AEH-8RFFX*	1/2	13/16 - 16	3.40	1.89	0.39		
N12C2AEH-12RFFX*	3/4	1-3/16 - 12	4.05	2.18	0.61		
N16C2AEH-16RFFX*	1	1-7/16 - 12	4.78	2.73	0.82		

To order: Insert Stems only i.e., N4C2AEH-4R-I-FJX-S6NP⁽²⁾ Class 3⁽¹⁾
Sockets only i.e., N4C2AEH-4R-SK-CN⁽²⁾-Class 3⁽¹⁾

*Insert Material Code
(for details see page 8).

(1) If applicable, insert suffix Class (1, 2 or 3)
Special note: For Class 6; B31.1; B31.3, leave Code Class blank i.e., N4C2AEH-4R-SK-CN⁽²⁾

(2) Material Code details see page 8

I= Reusable insert stems
R-SK= Reusable socket

Model M2 Mighty-Crimp Hose Coupling System for Models NC2AH & NC2AEH

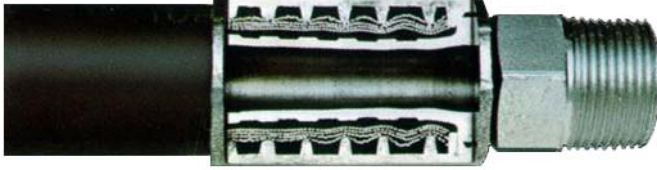

- 360° crimp extra-holding power
- High-flow orifice - Minimum pressure drop
- 316SS SA479 code material corrosion resistant reliability
- Compatible with ASME Section III, VIII, B31.1 and CSA N285.2

Thorburn Mighty-Crimp is the world's finest fitting to hose attachment system. Mighty-Crimp is designed and built to specifications for optimum interface compatibility and has been verified by the most rigorous tests in the industry. When you specify Thorburn Mighty-Crimp couplings on Thorburn hoses, you are buying a performance-proven hose assembly system.

TYPICAL MIGHTY-CRIMP ASSEMBLIES

*Female 37° JIC swivel
Model FJX*

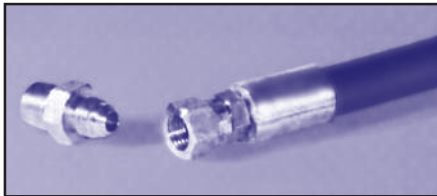

*Flat face O-Seal swivel
Model FFX*



*Compression tube assembly
Swagelok/Parker compatible
Model TAN*

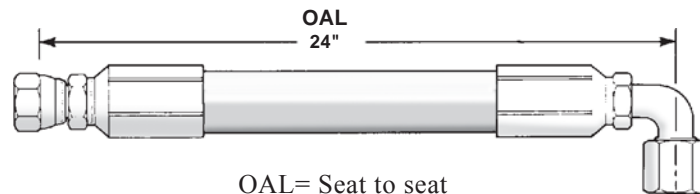
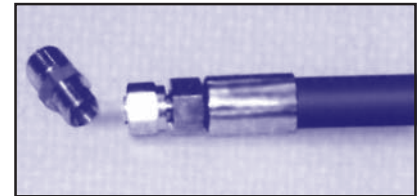

Tip to tip unless specified otherwise

HOW TO ORDER THORBURN MIGHTY-CRIMP HOSE COUPLING ASSEMBLY

Size / Hose	Crimp Series	1st End Size/Type Coupling	1st End Material*	2nd End Size/Type Coupling	2nd End Material*	O.A.L. Inches
NC12C2AH	M2	12FFX	S6	12MP	S6	480

Size and type of hose

N16TA Air/Water (page 14)
N30TS Steam (page 15)
NC2ATH High pressure Buna "N" (page 6)
NC2AEH High pressure EPDM (page 8)

Crimp

Use crimp Series M2
Use crimp Series M2
Use crimp Series M2
Use crimp Series M2

Coupling Type

Male NPTF
Male pipe union
Female 37° swivel
Flat face "O" swivel
Male JIC
Male O-Ring boss
Tube adapter ass'y
Tube adapter with nuts & ferrules
Bent tube 90° Short neck
Bent tube 90° Long neck

Code

MP
MPU (not shown)
FJX
FFX
MJ
MB
TA
TAN
FJX90S
FJX90L

Material

* 316SS A479 (Code S6) standard. Other materials available upon request.

SPECIAL NOTE: Nominal hose & coupling sizes listed in 1/16"; i.e. 12 = 3/4", 6 = 3/8", etc.

Mighty-Crimp Series M2

For Models NC2AH & NC2AEH

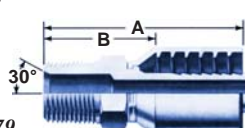
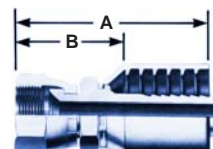
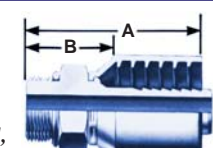
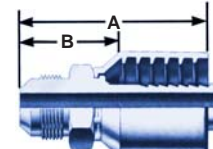
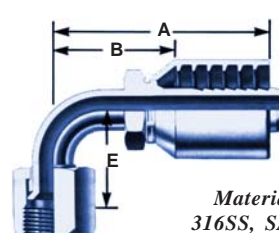
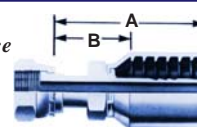
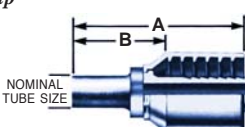
Thorburn Part Number	Hose Size (in.)	Thread Size (in.)	A (in.)	B (in.)	E (in.)	
N4M2-4MPS6 N6M2-6MPS6 N8M2-8MPS6 N12M2-12MPS6 N16M2-16MPS6 N20M2-20MPS6 N24M2-24MPS6 N32M2-32MPS6	1/4 3/8 1/2 3/4 1 1-1/4 1-1/2 2	1/4 - 18 3/8 - 18 1/2 - 14 3/4 - 14 1 - 11-1/2 1-1/4 - 11-1/2 1-1/2 - 11-1/2 2 - 11-1/2	2.23 2.54 2.89 3.22 3.69 4.39 4.82 5.86	1.14 1.21 1.45 1.51 1.98 2.09 2.18 2.33		<p>Mighty-Crimp Series M2 Male NPTF</p>  <p>Material: 316SS, SA479</p>
N4M2-4FJXS6 N6M2-6FJXS6 N8M2-8FJXS6 N12M2-12FJXS6 N16M2-16FJXS6 N20M2-20FJXS6 N24M2-24FJXS6 N32M2-32FJXS6	1/4 3/8 1/2 3/4 1 1-1/4 1-1/2 2	7/16 - 20 9/16 - 18 3/4 - 16 1-1/16 - 12 1-5/16 - 12 1-5/8 - 12 1-7/8 - 12 2-1/2 - 12	2.13 2.24 2.76 3.39 3.63 4.58 5.10 6.45	1.04 1.22 1.32 1.68 1.92 2.28 2.46 2.92		<p>Mighty-Crimp Series M2 Female 37° (JIC) Swivel</p>  <p>Material: 316SS, SA479</p>
N4M2-4MBS6 N6M2-6MBS6 N8M2-8MBS6 N12M2-12MBS6 N16M2-16MBS6 N20M2-20MBS6	1/4 3/8 1/2 3/4 1 1-1/4	7/16 - 20 9/16 - 18 3/4 - 16 1-1/16 - 12 1-5/16 - 12 1-5/8 - 12	2.09 2.10 2.61 3.27 3.34 3.90	1.00 1.09 0.91 1.30 1.28 1.60		<p>Mighty-Crimp Series M2 Male "O" Ring Boss</p>  <p>Material: 316SS, SA479</p>
N4M2-4MJS6 N6M2-6MJS6 N8M2-8MJS6 N12M2-12MJS6 N16M2-16MJS6 N20M2-20MJS6	1/4 3/8 1/2 3/4 1 1-1/4	7/16 - 20 9/16 - 18 3/4 - 16 1-1/16 - 12 1-5/16 - 12 1-5/8 - 12	2.22 2.16 2.80 3.41 3.66 4.38	1.13 1.15 1.36 1.70 1.95 2.08		<p>Mighty-Crimp Series M2 Male 37° (JIG)</p>  <p>Material: 316SS, SA479</p>
SHORT STEM N4M2-4FJX90SS6 N6M2-6FJX90SS6 N8M2-8FJX90SS6 N12M2-12FJX90SS6 N16M2-16FJX90SS6	1/4 3/8 1/2 3/4 1	7/16 - 20 9/16 - 18 3/4 - 16 1-1/16 - 12 1-5/16 - 12	1.74 2.13 2.88 3.74 3.55	1.44 1.81 1.93 2.81 3.55	0.68 0.85 1.09 1.82 2.14	<p>Mighty-Crimp Series M2 Female 37° (JIC) swivel 90° bent tube</p>  <p>Material: 316SS, SA479</p>
LONG STEM N4M2-4FJX90LS6 N6M2-6FJX90LS6 N8M2-8FJX90LS6 N12M2-12FJX90LS6 N16M2-16FJX90LS6	1/4 3/8 1/2 3/4 1	7/16 - 20 9/16 - 18 3/4 - 16 1-1/16 - 12 1-5/16 - 12	1.74 2.13 2.88 3.74 3.55	1.44 1.81 1.93 2.81 3.55	1.80 2.18 2.43 3.73 4.58	
N4M2-4FFXS6 N6M2-6FFXS6 N8M2-8FFXS6 N12M2-12FFXS6 N16M2-16FFXS6	3/8 1/2 3/4 1 1-1/4	11/16 - 16 13/16 - 16 1-3/16 - 12 1-7/16 - 12 1-11/16 - 12	2.32 2.88 3.91 4.42 5.27	1.29 1.41 1.90 2.13 2.37		<p>Mighty-Crimp Series M2 Flat face "O" ring swivel</p>  <p>Material: 316SS, SA479</p>
N4M2-4TAS6 N6M2-6TAS6 N8M2-8TAS6 N12M2-12TAS6 N16M2-16TAS6	1/4 3/8 1/2 3/4 1	Tube Size 1/4 3/8 1/2 3/4 1	2.00 2.52 2.68 3.19 3.82	1.10 1.14 1.42 1.57 2.01		<p>Mighty-Crimp Series M2 O.D. tube assembly</p>  <p>Material: 316SS, SA479</p>

Model NC12

Reinforced Very High-Pressure Elastomeric Hose



APPLICATIONS

Very high-pressure hydraulic applications. Excellent impulse life. Surpassed 1,000,000 impulse cycles at 133% of design pressure at 250°F. Thorburn NC12 can meet the requirements of ASME Section III, VIII and B31.1 when installed by Thorburn with its Mighty-Crimp factory assembled extra high pressure coupling system. Radiation resistance of elastomer materials 6×10^7 Roentgens.

CONSTRUCTION

Tube: Type A black chloroprene oil resistant synthetic rubber blend.

Reinforcement: Four alternating layers of spiraled high tensile steel wire.

Cover: Type A black/grey chloroprene synthetic rubber blend. Oil, abrasion and ozone resistant.

Temperature: -40°F (40°C) to 250°F (121°C).

Couplings: Thorburn's Mighty-Crimp Series M4.

Hose compatibility: Aeroquip FC250A.

Thorburn Part Number	Hose I.D.		Hose O.D.		Design Press.		Minimum Burst Press.		Minimum Bend Radius		Weight	
	mm	in.	mm	in.	MPa	psi	MPa	psi	mm	in.	kg/100 m	lbs/100 ft
N8C12	12.5	1/2	23.9	0.94	27.6	4000	110.3	16000	178	7.0	86	58
N12C12	19.0	3/4	30.7	1.21	27.6	4000	110.3	16000	241	9.5	137	92
N16C12	25.0	1	39.7	1.50	27.6	4000	110.3	16000	305	12.0	189	127
N20C12	31.5	1-1/4	47.5	1.85	20.7	3000	82.7	12000	419	16.5	267	179
N24C12	38.0	1-1/2	54.1	2.13	17.2	2500	68.9	10000	508	20.0	285	191
N32C12	51.0	2	67.3	2.63	17.2	2500	68.9	10000	635	25.0	412	277

SPECIAL NOTE: Design pressures available to 5,000 psi for all sizes listed above. Specify Thorburn model NC13 on request

HOW TO ORDER THORBURN NC12 HOSE ASSEMBLIES

Size Hose	Crimp Series	1st End Size/Coupling	1st End Material	2nd End Size/Coupling	2nd End Material	Length Inches
N12C12	M4	12FJX	S6	12MP	S6	480

SPECIAL NOTE: Nominal hose & coupling sizes listed in 1/16"; i.e. 12 = 3/4", 6 = 3/8", etc.

Description:

3/4" NC12 hose c/w 3/4" Mighty-Crimp Series M4 female 37° swivel in 316SS, other end 3/4" male NPTF in 316SS, 480" O.A.L.

AVAILABLE COUPLING MATERIAL

Material	ASME	CODES
SS316	SA479	S6
Steel	A108, SA695 S696, SA739 (special)	CC

Mighty-Crimp Series M4 For Model NC12

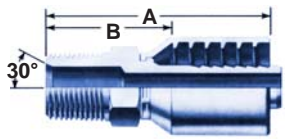
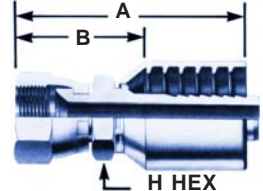
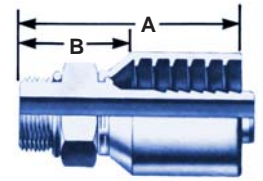
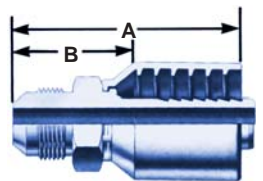
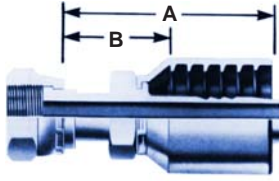
Thorburn Part Number	Hose Size (in.)	Thread Size (in.)	A (in.)	B (in.)	Coupling Type
N8M4-8MPS6 N12M4-12MPS6 N16M4-16MPS6 N20M4-20MPS6 N24M4-24MPS6 N32M4-32MPS6	1/2 3/4 1 1-1/4 1-1/2 2	1/2 - 14 3/4 - 14 1 - 11-1/2 1-1/4 - 11-1/2 1-1/2 - 11-1/2 2 - 11-1/2	2.900 3.550 4.157 4.981 5.140 5.876	1.420 1.542 1.921 2.181 2.340 2.331	<i>Mighty-Crimp Series M4 Male NPTF</i> 
N8M4-8FJXS6 N12M4-12FJXS6 N16M4-16FJXS6 N20M4-20FJXS6 N24M4-24FJXS6 N32M4-32FJXS6	1/2 3/4 1 1-1/4 1-1/2 2	3/4 - 16 1-1/16 - 12 1-5/16 - 12 1-5/8 - 12 1-7/8 - 12 2-1/2 - 12	2.800 3.769 4.134 5.290 5.420 6.580	1.330 1.760 1.900 2.490 2.620 3.030	<i>Mighty-Crimp Series M4 Female 37° (JIC) swivel</i> 
N8M4-8MBS6 N12M4-12MBS6 N16M4-16MBS6 N20M4-20MBS6	1/2 3/4 1 1-1/4	3/4 - 16 1-1/16 - 12 1-5/16 - 12 1-5/8 - 12	2.590 3.460 3.780 4.370	1.110 1.450 1.540 1.570	<i>Mighty-Crimp Series M4 Male "O" Ring Boss</i> 
N8M4-8MJS6 N12M4-12MJS6 N16M4-16MJS6 N20M4-20MJS6 N24M4-24MJS6 N32M4-32MJS6	1/2 3/4 1 1-1/4 1-1/2 2	3/4 - 16 1-1/16 - 12 1-5/16 - 12 1-5/8 - 12 1-7/8 - 12 2-1/2 - 12	2.810 3.660 4.100 4.910 5.040 6.140	1.330 1.660 1.860 2.110 2.240 1.590	<i>Mighty-Crimp Series M4 Male JIC 37° Flare</i> 
N8M4-8FFXS6 N12M4-12FFXS6 N16M4-12FFXS6 N20M4-20FFXS6 N24M4-24FFXS6	1/2 3/4 1 1-1/4 1-1/2	13/16 - 16 1-3/16 - 12 1-7/16 - 12 1-11/16 - 12 2 - 12	2.880 3.910 4.420 5.170 5.170	1.410 1.900 2.130 2.370 2.320	<i>Mighty-Crimp Series M4 Female Flat Face "O" Ring Swivel</i> 

HOW TO ORDER THORBURN MIGHTY-CRIMP SERIES M4 HOSE COUPLING SYSTEM

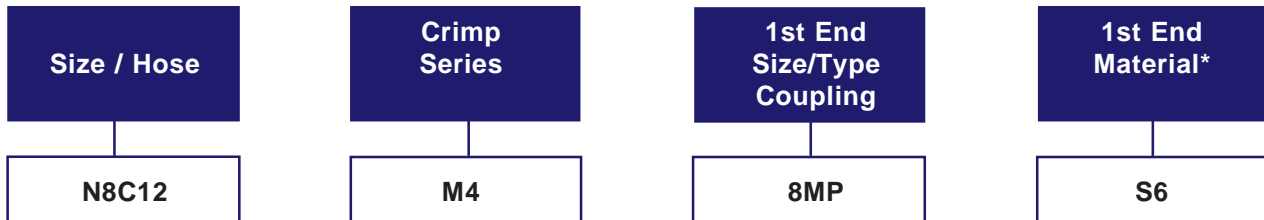

Coupling Type

Male NPTF _____ MP
 Female 37° swivel _____ FJX
 Flat face "O" swivel _____ FFX
 Male JIC _____ MJ
 Male O-Ring boss _____ MB

Code

Material Codes

* 316SS A479 (Code S6) standard.
 ** Also available carbon steel on request (Code CC)
 Other materials available upon request.

SPECIAL NOTE: Nominal hose & coupling sizes listed in 1/16"; i.e. 12 = 3/4", 6 = 3/8", etc.

Model NC13

Reinforced Very High-Pressure Elastomeric Hose



APPLICATIONS

Extremely high-pressure hydraulic applications. Recommended for high impulse applications. Surpasses SAE 100R13 impulse cycles at 133% of design pressure at 250°F. Thorburn NC13 can meet the requirements of ASME Section III, VIII and B31.1 when installed by Thorburn with its Mighty-Crimp factory assembled extra high pressure coupling system. Radiation resistance of elastomer materials 6×10^7 Roentgens.

CONSTRUCTION

Tube: Black oil resistant synthetic rubber blend.

Reinforcement: Four alternating layers of spiraled high tensile steel wire.

Cover: Black/Grey synthetic rubber blend. Oil, abrasion and ozone resistant.

Temperature: -40°F (40°C) to 250°F (121°C).

Couplings: Thorburn's Mighty-Crimp Series M5.

Hose compatibility: Aeroquip FC273.

Thorburn Part Number	Hose I.D.		Hose O.D.		Design Press.		Minimum Burst Press.		Minimum Bend Radius		Weight	
	mm	in.	mm	in.	MPa	psi	MPa	psi	mm	in.	kg/100 m	lbs/100 ft
N8C13	12.5	1/2	24.1	0.94	34.5	5000	138	20000	178	7.0	86	58
N12C13	19.0	3/4	31.5	1.24	34.5	5000	138	20000	241	9.5	161	108
N16C13	25.0	1	38.9	1.53	34.5	5000	138	20000	305	12.0	220	148
N20C13	31.5	1-1/4	50	1.97	34.5	5000	138	20000	419	16.5	372	250
N24C13	38.0	1-1/2	57.4	2.26	34.5	5000	138	20000	508	20.0	474	319
N32C13	51.0	2	67.3	2.80	34.5	5000	138	20000	635	25.0	728	490

HOW TO ORDER THORBURN NC13 HOSE ASSEMBLIES

Description:

3/4" NC13 hose c/w 3/4" Mighty-Crimp Series M5 female 37° swivel in 316SS, other end 3/4" male NPTF in 316SS, 480" O.A.L.

Size Hose	Crimp Series	1st End Size/Coupling	1st End Material	2nd End Size/Coupling	2nd End Material	Length Inches (OAL)
N12C13	M5	12FJX	S6	12MP	S6	480

SPECIAL NOTE: Nominal hose & coupling sizes listed in 1/16"; i.e. 12 = 3/4", 6 = 3/8", etc.

Coupling Type	Code
Male NPTF _____	MP
Female 37° swivel _____	FJX
Flat face "O" swivel _____	FFX
Male JIC _____	MJ
Male O-Ring boss _____	MB
Code 62 O-Ring Flange _____	FLH

Material Codes
* 316SS A479 (Code S6) standard.

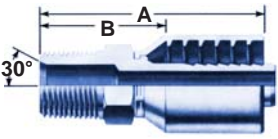
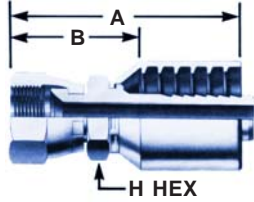
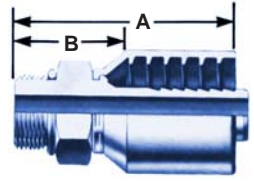
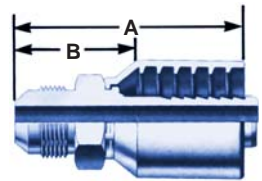
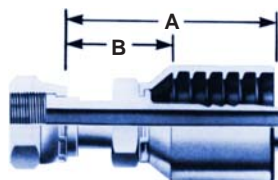
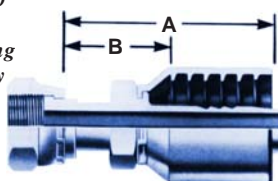

Mighty-Crimp Series M5 For Model NC13

Thorburn Part Number	Hose Size (in.)	Thread Size (in.)	A (in.)	B (in.)	Coupling type	
N8M5-8MPS6	1/2	1/2 - 14	2.900	1.420	<i>Mighty-Crimp Series M5 Male NPTF</i> 	
N12M5-12MPS6	3/4	3/4 - 14	3.550	1.542		
N16M5-16MPS6	1	1 - 11-1/2	4.157	1.921		
N20M5-20MPS6	1-1/4	1-1/4 - 11-1/2	4.981	2.181		
N24M5-24MPS6	1-1/2	1-1/2 - 11-1/2	5.76	2.23		
N32M5-32MPS6	2	2 - 11-1/2	6.21	2.38		
N8M5-8FJXS6	1/2	3/4 - 16	2.800	1.330	<i>Mighty-Crimp Series M5 Female 37° (JIC) swivel</i> 	
N12M5-12FJXS6	3/4	1-1/16 - 12	4.02	1.760		
N16M5-16FJXS6	1	1-5/16 - 12	4.37	1.900		
N20M5-20FJXS6	1-1/4	1-5/8 - 12	5.36	2.490		
N24M5-24FJXS6	1-1/2	1-7/8 - 12	6.25	2.72		
N32M5-32FJXS6	2	2-1/2 - 12	7.0	3.14		
N8M5-8MBS6	1/2	3/4 - 16	2.76	1.26	<i>Mighty-Crimp Series M5 Male "O" Ring Boss</i> 	
N12M5-12MBS6	3/4	1-1/16 - 12	3.66	1.65		
N16M5-16MBS6	1	1-5/16 - 12	3.86	1.62		
N20M5-20MBS6	1-1/4	1-5/8 - 12	4.53	1.73		
N8M5-8MJS6	1/2	3/4 - 16	2.83	1.36	<i>Mighty-Crimp Series M5 Male JIC 37° Flare</i> 	
N12M5-12MJS6	3/4	1-1/16 - 12	3.66	1.65		
N16M5-16MJS6	1	1-5/16 - 12	4.09	1.86		
N20M5-20MJS6	1-1/4	1-5/8 - 12	4.92	2.12		
N24M5-24MJS6	1-1/2	1-7/8 - 12	5.84	2.32		
N32M5-32MJS6	2	2-1/2 - 12	6.56	2.73		
N8M5-8FFXS6	1/2	13/16 - 16	2.87	1.40	<i>Mighty-Crimp Series M5 Female Flat Face "O" Ring Swivel</i> 	
N12M5-12FFXS6	3/4	1-3/16 - 12	3.90	1.89		
N16M5-12FFXS6	1	1-7/16 - 12	4.36	2.14		
N20M5-20FFXS6	1-1/4	1-11/16 - 12	5.04	2.24		
N24M5-24FFXS6	1-1/2	2 - 12	5.99	2.46		
Thorburn Part Number	Hose Size (in)	"M" Flange Dia	"H" Flange Head Thickness	A (in)	B (in)	Coupling type
N8M5-8FLHS6	1/2	1.25	0.31	3.66	2.19	<i>Mighty-Crimp Series M5 Code 62 O-Ring Flange Heavy</i> 
N12M5-12FLHS6	3/4	1.63	0.35	4.49	2.48	
N16M5-16FLHS6	1	1.88	0.38	4.92	2.70	
N20M5-20FLHS6	1-1/4	2.13	0.41	5.75	2.95	
N24M5-24FLHS6	1-1/2	2.50	0.56	7.15	5.47	
N32M5-32FLHS6	2	3.13	0.56	8.00	3.95	

1. Also Available in Code 61 O-Ring Flange and Bent Stems (POR)
2. Female JIC swivels available in bent stems (POR)
3. Not all assemblies have CRN but available (POR)

AVAILABLE COUPLING MATERIAL		
Material	ASME	CODES
SS316	SA479	S6

Model NC15

Reinforced Very High-Pressure Elastomeric Hose



APPLICATIONS

Extremely high-pressure hydraulic applications. Recommended where the pressure requirements exceed 5000 psi. Thorburns NC15 is also recommended for high impulse applications. This hose surpasses SAE 100R15 impulse cycles at 133% of design pressure at 250°F. Thorburn NC15 can meet the requirements of ASME Section III, VIII and B31.1 when installed by Thorburn with its Mighty-Crimp factory assembled extra high pressure coupling system. Radiation resistance of elastomer materials 6×10^7 Roentgens.

CONSTRUCTION

- Tube:** Black oil resistant synthetic rubber blend.
- Reinforcement:** Four alternating layers of spiraled high tensile steel wire.
- Cover:** Black/grey synthetic rubber blend. Oil, abrasion and ozone resistant.
- Temperature:** -40°F (40°C) to 250°F (121°C).
- Couplings:** Thorburn's Mighty-Crimp Series M6.
- Hose compatibility:** Aeroquip FC606.

Thorburn Part Number	Hose I.D.		Hose O.D.		Design Press.		Minimum Burst Press.		Minimum Bend Radius		Weight	
	mm	in.	mm	in.	MPa	psi	MPa	psi	mm	in.	kg/100 m	lbs/100 ft
N8C15	12.5	1/2	24.1	0.95	41.3	6000	165.5	24000	178	7.0	86	58
N12C15	19.0	3/4	31.5	1.24	41.3	6000	165.5	24000	241	9.5	161	108
N16C15	25.0	1	38.9	1.53	41.3	6000	165.5	24000	305	12.0	220	148
N20C15	31.5	1-1/4	50	1.97	41.3	6000	165.5	24000	419	16.5	372	250
N24C15	38.0	1-1/2	57.4	2.26	41.3	6000	165.5	24000	508	20.0	474	319

HOW TO ORDER THORBURN NC15 HOSE ASSEMBLIES

Description:

3/4" NC15 hose c/w 3/4" Mighty-Crimp Series M6 female 37° swivel in 316SS, other end 3/4" male NPTF in 316SS, 480" O.A.L.

Size Hose	Crimp Series	1st End Size/Coupling	1st End Material	2nd End Size/Coupling	2nd End Material	Length Inches (OAL)
N12C15	M5	12FJX	S6	12MP	S6	480

SPECIAL NOTE: Nominal hose & coupling sizes listed in 1/16"; i.e. 12 = 3/4", 6 = 3/8", etc.

Coupling Type	Code
Male NPTF _____	MP
Female 37° swivel _____	FJX
Flat face "O" swivel _____	FFX
Male JIC _____	MJ
Male O-Ring boss _____	MB
Code 62 O-Ring Flange _____	FLH

Material Codes
* 316SS A479 (Code S6) standard

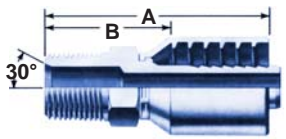
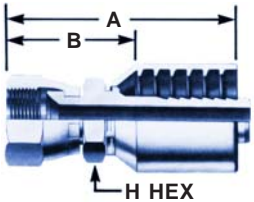
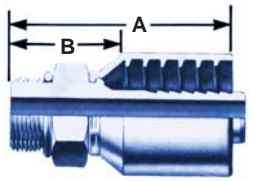
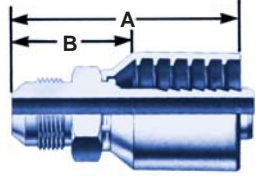
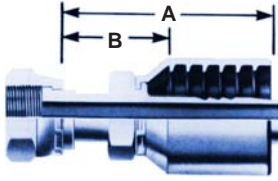
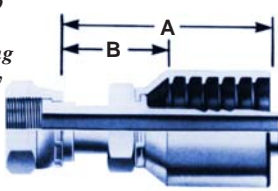

Mighty-Crimp Series M6 For Model NC15

Thorburn Part Number	Hose Size (in.)	Thread Size (in.)	A (in.)	B (in.)	Coupling type	
N8M6-8MPS6 N12M6-12MPS6 N16M6-16MPS6 N20M6-20MPS6 N24M6-24MPS6 N32M6-32MPS6	1/2 3/4 1 1-1/4 1-1/2 2	1/2 - 14 3/4 - 14 1 - 11-1/2 1-1/4 - 11-1/2 1-1/2 - 11-1/2 2 - 11-1/2	2.900 3.550 4.157 4.981 5.140 5.876	1.420 1.542 1.921 2.181 2.340 2.331	Mighty-Crimp Series M6 Male NPTF 	
N8M6-8FJXS6 N12M6-12FJXS6 N16M6-16FJXS6 N20M6-20FJXS6 N24M6-24FJXS6 N32M6-32FJXS6	1/2 3/4 1 1-1/4 1-1/2 2	3/4 - 16 1-1/16 - 12 1-5/16 - 12 1-5/8 - 12 1-7/8 - 12 2-1/2 - 12	2.800 3.769 4.134 5.290 5.420 6.580	1.330 1.760 1.900 2.490 2.620 3.030	Mighty-Crimp Series M6 Female 37° (JIC) swivel 	
N8M6-8MBS6 N12M6-12MBS6 N16M6-16MBS6 N20M6-20MBS6	1/2 3/4 1 1-1/4	3/4 - 16 1-1/16 - 12 1-5/16 - 12 1-5/8 - 12	2.590 3.460 3.780 4.370	1.110 1.450 1.540 1.570	Mighty-Crimp Series M6 Male "O" Ring Boss 	
N8M6-8MJS6 N12M6-12MJS6 N16M6-16MJS6 N20M6-20MJS6 N24M6-24MJS6 N32M6-32MJS6	1/2 3/4 1 1-1/4 1-1/2 2	3/4 - 16 1-1/16 - 12 1-5/16 - 12 1-5/8 - 12 1-7/8 - 12 2-1/2 - 12	2.810 3.660 4.100 4.910 5.040 6.140	1.330 1.660 1.860 2.110 2.240 1.590	Mighty-Crimp Series M6 Male JIC 37° Flare 	
N8M6-8FFXS6 N12M6-12FFXS6 N16M6-12FFXS6 N20M6-20FFXS6 N24M6-24FFXS6	1/2 3/4 1 1-1/4 1-1/2	13/16 - 16 1-3/16 - 12 1-7/16 - 12 1-11/16 - 12 2 - 12	2.880 3.910 4.420 5.170 5.170	1.410 1.900 2.130 2.370 2.320	Mighty-Crimp Series M6 Female Flat Face "O" Ring Swivel 	
Thorburn Part Number	Hose Size (in)	"M" Flange Dia	"H" Flange Head Thickness	A (in)	B (in)	Coupling type
N8M6-8FLHS6 N12M6-12FLHS6 N16M6-16FLHS6 N20M6-20FLHS6 N24M6-24FLHS6 N32M6-32FLHS6	1/2 3/4 1 1-1/4 1-1/2 2	1.25 1.63 1.88 2.13 2.50 3.13	0.31 0.35 0.38 0.41 0.56 0.56	3.66 4.49 4.92 5.75 7.15 8.00	2.19 2.48 2.70 2.95 5.47 3.95	Mighty-Crimp Series M5 Code 62 O-Ring Flange Heavy 

1. Also Available in Code 61 O-Ring Flange and Bent Stems (POR)
2. Female JIC swivels available in bent stems (POR)
3. Not all assemblies have CRN but available (POR)

N16TA Multi-Purpose Transfer Hose

Thorburn's Model N16TA was specifically designed for heavy duty high pressure pneumatic air and/or water service. It is an ideal hose to provide power to air operated equipment (i.e. bull lines, jack hammer, boring, drills and mining equipment) found in the drilling, construction, mining and power generating industries.

Thorburn's Model N16TA assemblies are registered to ASME B31.1. It is an ideal "bull hose" to withstand severe external abuse and internal surge pressures while providing excellent resistance to nuclear radiation exposure of 6×10^7 Roentgens.

CONSTRUCTION

Tube: Black oil resistant, heat resistant neoprene or nitrile synthetic rubber.

Reinforcement: Multi-ply or calendered polyester fabric or single or multi high tensile wire braid(s).

Cover: Bright yellow, heavy gauge, oil resistant, abrasion resistant neoprene "CR"

Couplings: Heavy duty interlocking with reusable bolted clamps or Thorburn Mighty-Crimp available in ASME Section II code materials such as ductile iron, steel or stainless. For coupling details, please see pages 16 and 17.

Lengths: Standard 50'. Available in continuous lengths of 400'.

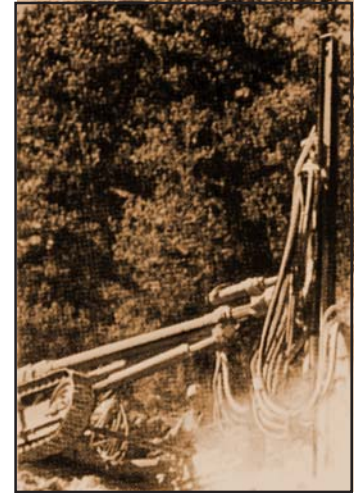
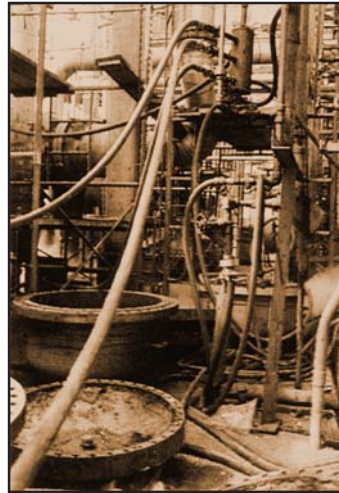

Thorburn Part Number	Hose I.D.		Hose O.D.		Design Pressure at 180°F (82°C)		Minimum Burst Pressure		Minimum Bend Radius		Weight	
	mm	in.	mm	in.	MPa	psi	MPa	psi	mm	in.	kg/100 m	lbs/100 ft
N16TA08	12.7	1/2	26.5	1.04	2.75	400	11.04	1600	127	5.00	74	50
N16TA12	19.1	3/4	32.5	1.28	2.75	400	11.04	1600	191	7.50	107	72
N16TA16	25.4	1	38.9	1.53	2.75	400	11.04	1600	254	10.00	123	83
N16TA20	31.8	1-1/4	46.2	1.81	2.07	300	8.28	1200	318	12.50	172	116
N16TA24	38.1	1-1/2	52.4	2.06	2.07	300	8.28	1200	457	18.00	202	136
N16TA32	50.8	2	65.9	2.75	2.07	300	8.28	1200	610	24.00	362	241
N16TA40	63.5	2-1/2	85.0	3.23	1.70	250	6.90	1000	787	31.00	437	293
N16TA48	76.2	3	92.9	3.60	1.70	250	6.90	1000	889	35.00	490	329
N16TA64	101.6	4	120.7	4.75	1.70	250	6.90	1000	1067	42.00	679	456

SPECIAL NOTE: Nominal hose & coupling sizes listed in 1/16"; i.e. 12 = 3/4", 6 = 3/8", etc.

N30TS Steam, D2O & Air Lock Transfer Hose

Thorburn's Model N30TS was specifically designed for heavy duty steam cleaning service using saturated steam at pressures to 250 psi and temperatures to 406°F. Thorburn's Model 30TS will also handle superheated steam to 250 psi and 450°F. This exceptionally strong and versatile hose is built to withstand constant usage and give long, dependable service under the toughest conditions, yet it is the industry's most flexible and easiest hose to handle.

It is the ideal hose for the nuclear power generating industry due to its excellent materials radiation resistance of 3×10^8 Roentgens.

Thorburn's Model N30TS assemblies are registered in each province to ASME B31.1.



APPLICATIONS

- Transfer of steam for processing products and cleaning equipment
- Transfer of steam or hot water, hot 200°F detergent (non oil based) solutions for cleaning of equipment, tasks, building
- Transfer steam to melt glues, waxes, etc.

CONSTRUCTION

Tube: Black heat resistant EPDM blend, specifically compounded to withstand high quality and super heated steam. Will not crack or harden during normal life of the hose.

Reinforcement: Two spiral braids with a textile anchor braid to provide excellent cover adhesion. Special spiral construction yields outstanding flexibility and great strength. Built-in static wire. Grounds any static build-up in the hose.

Cover: Type "M" EPDM. Red cover. Specifically compounded to provide excellent resistance to weathering, aging and eliminates premature cracking caused by the high temperatures encountered in steam service.

Pressure temperature: 1.7 MPa (250 psi) and 208°C (406°F).

Couplings: Heavy duty interlocking with reusable bolted clamps and/or Thorburn Mighty-Crimp.

Lengths: 25', 50', 100', 200' and 400'

Thorburn Part Number	Hose I.D.		Hose O.D.		Rated W.P.		Weight		Minimum Bend Radius	
	mm	in.	mm	in.	MPa	PSI	kg/100 m	lbs/100 ft	mm	in.
N30TS08	12.7	1/2	25.4	1.00	1.7	250	53.6	36	177.8	4.0
N30TS12	19.1	3/4	31.7	1.25	1.7	250	74.5	50	241.3	9.5
N30TS16	25.4	1	38.1	1.50	1.7	250	104.3	70	304.8	12.0
N30TS20	31.8	1-1/4	47.0	1.85	1.7	250	150.5	101	419.1	16.5
N30TS24	38.1	1-1/2	54.9	2.16	1.7	250	186.2	125	508.0	20.0
N30TS32	50.8	2	67.8	2.67	1.7	250	245.8	165	635.0	25.0
N30TS40	63.5	2-1/2	81.8	3.22	1.7	250	290.0	200	762.0	30.0
N30TS48	76.2	3	96.0	3.78	1.7	250	506.6	340	1016.0	40.0

WARNING: Exposure to steam is hazardous. If not properly controlled, steam can cause property damage, serious bodily injury or death. In order to avoid property damage, serious injury or death, you must select the proper steam hose for the given application. Also, proper installation, usage and maintenance of Thorburn steam hose you select will contribute to increased operator safety.

SPECIAL NOTE: Nominal hose & coupling sizes listed in 1/16"; i.e. 12 = 3/4", 6 = 3/8", etc.

Ground Joint Heavy Duty High Pressure Couplings and Clamps for N16TA/N30TS

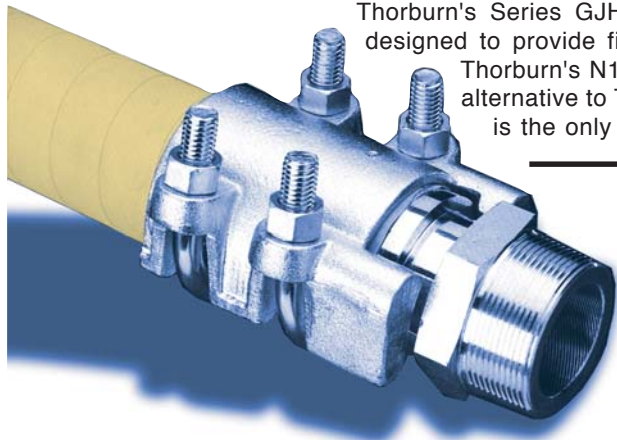

Thorburn's Series GJHD ground joint heavy duty high pressure couplings system is designed to provide fitting to end joint leak-tight sealing up to the burst pressure of Thorburn's N16TA/N30TS hoses. Thorburn's Series GJHD is a field attachable alternative to Thorburn's Mighty-Crimp factory assembled fitting to end joint and is the only coupling system available for sizes 2-1/2", 3" and 4".



FEMALE NPT SPUD SWIVEL



RIGID HEX MALE NPT

Thorburn Part #	Hose I.D.		Female Thread size	Length
	mm	in.	in.	in.
N17F-08*	13	1/2	1/2 - 14	3.7
N17F-12*	19	3/4	3/4 - 14	4.8
N17F-16*	25	1	1 - 11-1/2	5.3
N17F-20*	32	1-1/4	1-1/4 - 11-1/2	7.0
N17F-24*	38	1-1/2	1-1/2 - 11-1/2	7.2
N17F-32*	51	2	2 - 11-1/2	8.0
N17F-40*	64	2-1/2	2-1/2 - 8	8.8
N17F-48*	76	3	3 - 8	9.8
N17F-64*	102	4	4 - 8	11.2

Thorburn Part #	Hose I.D.		Male Thread size	Length
	mm	in.	in.	in.
N23M-08*	13	1/2	1/2 - 14	3
N23M-12*	19	3/4	3/4 - 14	4
N23M-16*	25	1	1 - 11-1/2	4.6
N23M-20*	32	1-1/4	1-1/4 - 11-1/2	6.2
N23M-24*	38	1-1/2	1-1/2 - 11-1/2	6.3
N23M-32*	51	2	2 - 11-1/2	6.9
N23M-40*	64	2-1/2	2-1/2 - 8	8.4
N23M-48*	76	3	3 - 8	9.1
N23M-64*	102	4	4 - 8	10.1

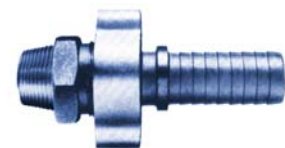

MALE NPT SPUD SWIVEL

Thorburn Part #	Hose I.D.		Male Thread size	Length
	mm	in.	in.	in.
N21M-08*	13	1/2	1/2 - 14	4.2
N21M-12*	19	3/4	3/4 - 14	5.5
N21M-16*	25	1	1 - 11-1/2	6.5
N21M-20*	32	1-1/4	1-1/4 - 11-1/2	7.5
N21M-24*	38	1-1/2	1-1/2 - 11-1/2	8.0
N21M-32*	51	2	2 - 11-1/2	8.8
N21M-40*	64	2-1/2	2-1/2 - 8	9.5
N21M-48*	76	3	3 - 8	10.7
N21M-64*	102	4	4 - 8	12.2

HIGH PRESSURE CLAMPS

Thorburn Part #	Hose O.D. with Heavy Duty Clamp	
	From	To
N8HDC*	0.93	1.06
N12HDC*	1.13	1.40
N16HDC*	1.40	1.70
N20HDC*	1.70	2.10
N24HDC*	1.95	2.20
N32HDC*	2.50	2.80
N40HDC*	3.25	3.70
N48HDC*	3.50	4.10
N60HDC*	4.20	4.8



* Insert material code

For ordering information, see page 22

Mighty-Crimp Series M2A

For Models N16TA & N30TS

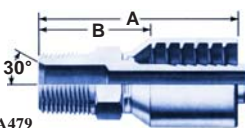
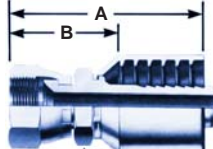
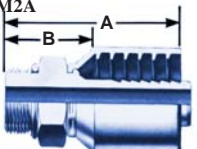
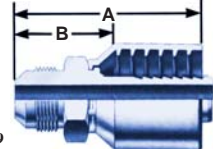
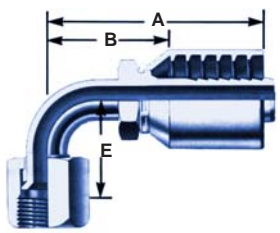
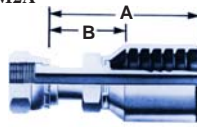
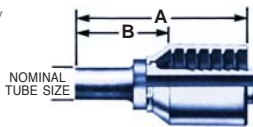
Thorburn Part Number	Hose Size (in.)	Thread Size (in.)	A (in.)	B (in.)	E (in.)	
N4M2A-4MPS6 N6M2A-6MPS6 N8M2A-8MPS6 N12M2A-12MPS6 N16M2A-16MPS6 N20M2A-20MPS6 N24M2A-24MPS6 N32M2A-32MPS6	1/4 3/8 1/2 3/4 1 1-1/4 1-1/2 2	1/4 - 18 3/8 - 18 1/2 - 14 3/4 - 14 1 - 11-1/2 1-1/4 - 11-1/2 1-1/2 - 11-1/2 2 - 11-1/2	2.23 2.54 2.89 3.22 3.69 4.39 4.82 5.86	1.14 1.21 1.45 1.51 1.98 2.09 2.18 2.33		Mighty-Crimp Series M2A Male NPTF  Material: 316SS, SA479
N4M2A-4FJXS6 N6M2A-6FJXS6 N8M2A-8FJXS6 N12M2A-12FJXS6 N16M2A-16FJXS6 N20M2A-20FJXS6 N24M2A-24FJXS6 N32M2A-32FJXS6	1/4 3/8 1/2 3/4 1 1-1/4 1-1/2 2	7/16 - 20 9/16 - 18 3/4 - 16 1-1/16 - 12 1-5/16 - 12 1-5/8 - 12 1-7/8 - 12 2-1/2 - 12	2.13 2.24 2.76 3.39 3.63 4.58 5.10 6.45	1.04 1.22 1.32 1.68 1.92 2.28 2.46 2.92		Mighty-Crimp Series M2A Female 37° (JIC) Swivel  Material: 316SS, SA479
N4M2A-4MBS6 N6M2A-6MBS6 N8M2A-8MBS6 N12M2A-12MBS6 N16M2A-16MBS6 N20M2A-20MBS6	1/4 3/8 1/2 3/4 1 1-1/4	7/16 - 20 9/16 - 18 3/4 - 16 1-1/16 - 12 1-5/16 - 12 1-5/8 - 12	2.09 2.10 2.61 3.27 3.34 3.90	1.00 1.09 0.91 1.30 1.28 1.60		Mighty-Crimp Series M2A Male "O" Ring Boss  Material: 316SS, SA479
N4M2A-4MJS6 N6M2A-6MJS6 N8M2A-8MJS6 N12M2A-12MJS6 N16M2A-16MJS6 N20M2A-20MJS6	1/4 3/8 1/2 3/4 1 1-1/4	7/16 - 20 9/16 - 18 3/4 - 16 1-1/16 - 12 1-5/16 - 12 1-5/8 - 12	2.22 2.16 2.80 3.41 3.66 4.38	1.13 1.15 1.36 1.70 1.95 2.08		Mighty-Crimp Series M2A Male 37° (JIC)  Material: 316SS, SA479
SHORT STEM N4M2A-4FJX90SS6 N6M2A-6FJX90SS6 N8M2A-8FJX90SS6 N12M2A-12FJX90SS6 N16M2A-16FJX90SS6	1/4 3/8 1/2 3/4 1	7/16 - 20 9/16 - 18 3/4 - 16 1-1/16 - 12 1-5/16 - 12	1.74 2.13 2.88 3.74 3.55	1.44 1.81 1.93 2.81 3.55	0.68 0.85 1.09 1.82 2.14	Mighty-Crimp Series M2A Female 37° (JIC) swivel 90° bent tube  Material: 316SS, SA479
LONG STEM N4M2A-4FJX90LS6 N6M2A-6FJX90LS6 N8M2A-8FJX90LS6 N12M2A-12FJX90LS6 N16M2A-16FJX90LS6	1/4 3/8 1/2 3/4 1	7/16 - 20 9/16 - 18 3/4 - 16 1-1/16 - 12 1-5/16 - 12	1.74 2.13 2.88 3.74 3.55	1.44 1.81 1.93 2.81 3.55	1.80 2.18 2.43 3.73 4.58	Mighty-Crimp Series M2A Flat face "O" ring swivel  Material: 316SS, SA479
N4M2A-4TAS6 N6M2A-6TAS6 N8M2A-8TAS6 N12M2A-12TAS6 N16M2A-16TAS6	1/4 3/8 1/2 3/4 1	Tube Size 1/4 3/8 1/2 3/4 1	2.00 2.52 2.68 3.19 3.82	1.10 1.14 1.42 1.57 2.01		Mighty-Crimp Series M2A O.D. tube assembly  Material: 316SS, SA479

Ground Joint Heavy Duty High Pressure Couplings and Clamps N16TA/N30TS

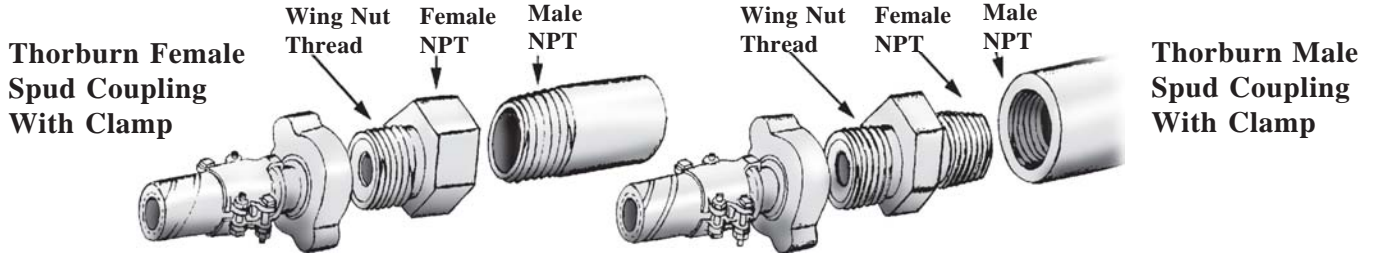

Material	ASTM/ASME	Code (M)
Plated Malleable Iron Casting	A47	MI
Plated Steel	A108	CC
316 Stainless Steel	SA479	S6

HOW TO ORDER COUPLINGS
N23M-08S6
for 1/2" I.D. solid male hex fitting in 316SS material.

HOW TO ORDER N16TA/N30TS HOSE ASSEMBLIES FROM COUPLINGS FOUND ON PAGE 16

Hose/Size	1st End Coupling/Size	1st End Material	2nd End Coupling/Size	2nd End Material	Length Inches
N30TS32	N21M-32	S6	N17F-32	S6	480"

SPECIAL NOTE: Nominal hose & coupling sizes listed in 1/16"; i.e. 12 = 3/4", 6 = 3/8", etc.

Also available with **Mighty Crimp series M2 Ends**— Please see pages 10 & 11 for details.

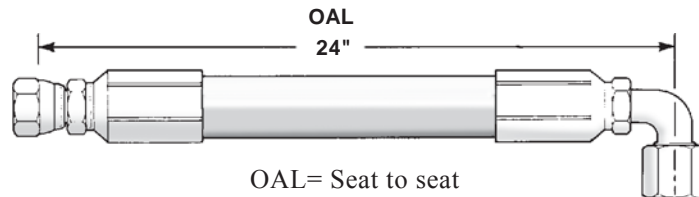

Tip to tip unless specified otherwise

HOW TO ORDER THORBURN MIGHTY-CRIMP N16TA AND N30TS HOSE COUPLING ASSEMBLIES

Size / Hose	Crimp Series	1st End Size/Type Coupling	1st End Material*	2nd End Size/Type Coupling	2nd End Material*	O.A.L. Inches
N16TA16	M2	16MPU	S6	16MP	S6	720

Size and type of hose

N16TA Air/Water (page 14)
N30TS Steam/Water (page 15)

Material

* 316SS A479 (Code S6) standard. Other materials available upon request.

SPECIAL NOTE: Nominal hose & coupling sizes listed in 1/16"; i.e. 12 = 3/4", 6 = 3/8", etc.

Crimp

Use crimp Series M2
Use crimp Series M2

Please see page 11 for coupling details

Coupling Type

Male NPTF
Male pipe union
Female 37° swivel
Flate face "O" swivel
Male JIC
Male O-Ring boss
Tube adapter ass'y
Tube adapter with nuts & ferrules
Bent tube 90° Short neck
Bent tube 90° Long neck

Code

MP
MPU (not shown on page 11)
FJX
FFX
MJ
MB
TA
TAN
FJX90S
FJX90L

N23TWX Ultra High Pressure Elastomeric Waterblast Hose Assemblies



WARNING: It is not recommended to use NPT threads greater than 10,000 psi service.

CONSTRUCTION

Tube: Special blend of smooth black butadiene acrylonitrile synthetic rubber.

Reinforcement: Four layers of high tensile spiraled steel wire with one high tensile braided wire over a layer of calendered polyester.

Cover: Black polychlorprene blend providing excellent abrasion and ozone resistance.

Couplings: Factory assembled crimp type quick coupling in stainless steel.

Temperature range: -40°F to 212°F (-40°C to 100°C).

Thorburn's Model N23TWX elastomeric hose assemblies are designed for extremely high pressure water cleaning equipment. Thorburn tests each N23TWX assembly to 15000 psi, tags and serializes for complete traceability. At Thorburn, we say "Quality goes in before the name goes on". Thorburn Model N23TWX hose assemblies are registered for 10,000 psi service as per ASME B31.1. Their elastomeric materials have a radiation resistance of 6×10^7 Roentgens. This hose is to be used for waterblast purposes only. Thorburn N23TWX is registered to ASME B31.1



Thorburn Part #	I.D.		O.D.		Design Pressure		Min. Burst Pressure		Min. Bend Radius		Weight	
	mm	in.	mm	in.	MPa	psi	MPa	psi	mm	in.	kg/100m	lbs/100ft.
N23TWX04	6.4	1/4	20.0	0.79	69	10000	310	45000	127	5	82.0	55
N23TWX06	9.5	3/8	21.0	0.81	69	10000	310	45000	152	6	89.5	60
N23TWX08	12.7	1/2	29.5	1.16	69	10000	310	45000	203	8	172.0	115



HOW TO ORDER THORBURN 23TWX HOSE ASSEMBLIES

Size Hose	1st End Size/Coupling	1st End Material	2nd End Size/Coupling	2nd End Material	Length Inches
N23TWX08	8MP	S6	8MP	S6	600

SPECIAL NOTE: Nominal hose & coupling sizes listed in 1/16"; i.e. 12 = 3/4", 6 = 3/8", etc.

For carbon steel material code C

Above 10,000 psi Thorburn recommends male cone and threaded or reverse high pressure connections.

Description:

1/2" N23TWX hose c/w 1/2" male pipe NPT in 316SS, other end 1/2" male pipe NPT in 316SS, 600" overall length. Also available with quick couplings. See page 23 for details.

Ultra-High Pressure Thermoplastic Water Blast Hose Assemblies Model N44TW



Thorburn's Model N44TW hose assemblies are designed to have advantages in particular applications over conventional steel reinforced elastomeric hose assemblies. The main advantages are light weight, long single lengths, small volume expansion, excellent chemical resistance.

Thorburn tests each N44TW assembly to 15,000 psi, tags and serializes for safety and is user friendly.

Thorburn N44TW is registered to ASME B31.1 for service at 10,000 psi.

CONSTRUCTION

Tube: Special blend of polyoxymethylen or polyamid PA, Delrin®, nylon 11/12

Reinforcement: 4 spiral wound layers of specially treated, high tensile steel wires

Outer cover: Polyamid PA, nylon 11/12

Couplings: Factory assembled Mighty Crimp type and Quick-Couplings



N44TW WATER BLAST HOSE SPECIFICATIONS

Thorburn Hose Part Number	I.D.		O.D.		Design Pressure		Min. Burst Pressure		Min. Bend Radius		Weight	
	mm	in.	mm	in.	MPa	psi	MPa	psi	mm	in.	kg/100 m	lb/100 ft
N44TW04	6.3	1/4	12.7	.50	69	10000	345	50000	178	7	30	20
N44TW06	9.5	3/4	17.3	.68	69	10000	317	46000	203	8	52	35
N44TW08	12.7	1/2	22	.85	69	10000	303	44000	203	8	84	56

HOW TO ORDER N44TW HOSE ASSEMBLIES

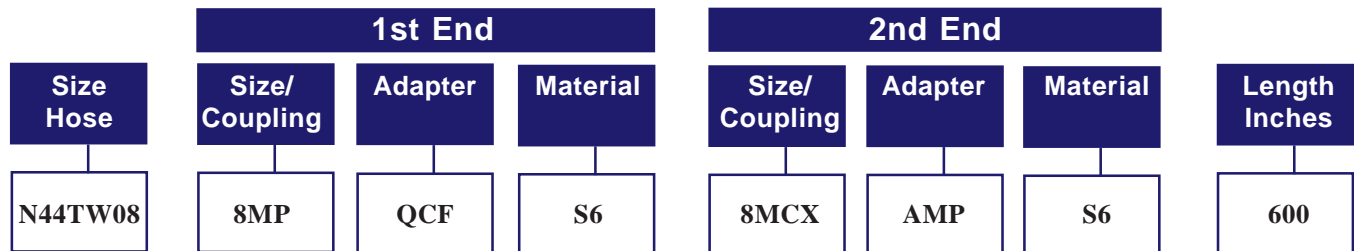

Adapter, quick disconnect coupler non-valved coupler female adapter

Code QCF



Male NPT coupling



58° male cone with swivel nut

Code MCX

Adapter, male cone with threaded tubing connector/reverse high pressure

Code AMC



Non valved nipple female adapter

Code QNF



All coupling and adapter material 316SS
All size and coupling and adapter in 1/16",
i.e.: 04 = 1/4

Male NPT connector/reverse high pressure

Code AMP



Series NQCH Quick-Disconnect Couplings

Thorburn's NQCH Series' fully engineered design meets or exceeds MIL-C-51234 and provides superior flow characteristics with built-in reliability. Thorburn's NQCH is registered to B31.1 and some couplings are registered ASME Section III. Thorburn also manufactures and supplies a proprietary higher pressure (3000 psi design 3/8", 3/4", 1") coupling, to meet the specific requirements for the CANDU fuelling machine head fluid system quick action coupling. Call Thorburn for details.

- **Low Pressure Drop**
- **Smooth Flow**
- **Shut-off on Disconnection**
- **Fast, Efficient Operation**
- **Positive Sealing Connected**
- **Positive Sealing Disconnected**

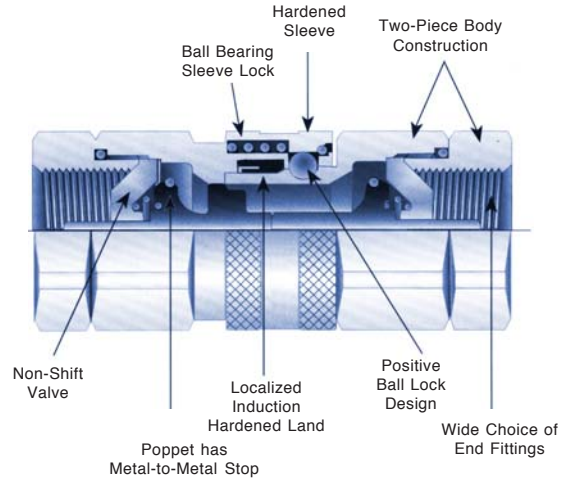

COUPLING COMBINATIONS & END FITTINGS

1. Double shut-off coupling: valve coupler and plain nipple.
2. Single shut-off coupling: valve coupler and plain nipple.
3. No shut-off or straight through: plain coupler and plain nipple. Plain couplers cannot be used with valve nipples.

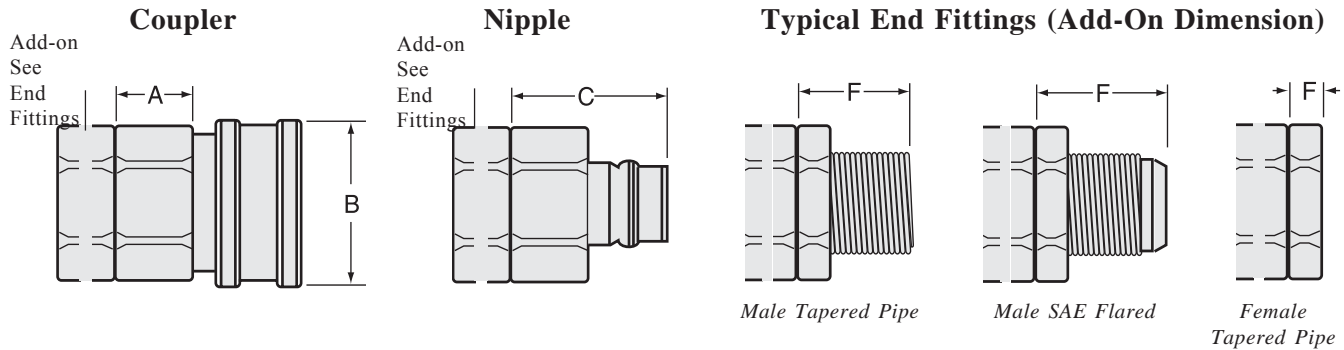

Size	1/4"	3/8"	1/2"	3/4"	1"	1-1/4"	1-1/2"	2"	2-1/2"	3"	4"
Valve⁽⁴⁾											
A	1.34	1.50	1.62	1.92	2.07	2.28	2.57	3.14	3.63	3.88	4.58
B	1.00	1.19	1.39	1.63	2.00	2.25	2.75	3.50	4.50	5.45	6.75
C	1.28	1.44	1.51	1.79	1.95	2.15	2.41	2.94	3.42	3.79	4.47
End Fittings⁽¹⁾ Add-on Dimensions											
<i>Male Tapered Pipe "M"</i>											
F	0.75	0.69	0.95	0.96	1.14	1.31	1.44	1.40	1.83	1.88	2.04
<i>Male SAE Flared and MS33656 "EM"</i>											
F	0.74	0.74	0.84	1.13	1.16	1.27	1.46	1.71			
<i>Female Tapered Pipe</i>											
F	0.31	0.40	0.47	0.50	0.60	1.26	0.70	0.78	0.90	0.88	1.13

- (1) Other special end fittings upon request.
- (2) Dimensions taken across the hex flats. Round stock with two milled flats may be substituted for hex stock. Dimensions across flats same as dimensions across hex flats. O.D. of round stock will not exceed the dimensions across the points of the hex stock.
- (3) 3.5" across hex flats – may be substituted 3.75 round with 3.38" across wrench flats.
- (4) Dimensions shown are for valve connections only. Non-valved couplers and nipple dimensions are slightly different. Please contact Thorburn.

Series NQCH Quick-Disconnect Couplings

Hydraulic, Pneumatic and General Purpose Use

Pressure and Flow Data Series "TH" Quick Couplings in 316SS

Quick Disconnect Size		Design Pressure Double Shut-Off		Burst Pressure		Design Pressure No Shut-Off		Burst Pressure	
mm	in.	bar	psi	bar	psi	bar	psi	bar	psi
6.25	1/4	172	2500	688	10000	345	5000	1380	20000
9.38	3/8	138	2000	552	8000	276	4000	1104	16000
12.50	1/2	129	1875	516	7500	276	4000	1104	16000
18.75	3/4	69	1000	276	4000	241	3500	964	14000
25.00	1	69	1000	276	4000	138	2000	552	8000
31.25	1-1/4	52	750	208	3000	103	1500	412	6000
37.50	1-1/2	52	750	208	3000	103	1500	412	6000
50.00	2	17	250	68	1000	34	500	136	2000
62.50	2-1/2	14	200	56	800	14	200	56	800
75.00	3	14	200	56	800	14	200	56	800
100.00	4	10	150	40	600	10	150	40	600

Note: Burst pressures listed were taken at the point at which failure made the coupling inoperative. Burst pressure is 4 times design. Proof pressure is 2 times design and test pressure is 1-1/2 times design.

Special note: 3000 psi design available for 3/8", 3/4", 1". Thorburn manufactures and supplies a proprietary higher pressure 3000 psi design for the NQCH sizes 3/8", 3/4", 1" to meet the specific requirements for the CANDU fuelling machine head fluid system quick action coupling, i.e. pressure, temperature, materials, spillage, air inclusion, leakage and pressure drop.

HOW TO ORDER

Series	Quick-Coupling Nom. I.D. Code	Quick-Coupling Nom. I.D. Size	Body Type Code	Coupling Half Code	End Fitting Code	End Fitting Size	Type of End Fitting Code	Seal Material Code	Sleeve Lock Code	Material Code
NQCH	4	= 1/4"	V= Valve	C= Coupler	2	= 1/8"	M= Male NPTF	B= Buna N	L	S6=
	6	= 3/8"	P= Straight through	N= Nipple	4	= 1/4"	F= Female NPTF	V= Viton (DuPont)	Aids in preventing accidental disconnection.	316SS
	8	= 1/2"			6	= 3/8"	EM= Male SAE 37° flare	E= EPDM Ethylene propylene rubber	To disconnect, align the pin in the body with the slot in the sleeve.	Other material available on request
	12	= 3/4"			10	= 5/8"	BF= Bulkhead Female NPT			
	16	= 1"			12	= 3/4"	BM= Bulkhead Male NPT			
	20	= 1-1/4"			16	= 1"				
	24	= 1-1/2"			20	= 1-1/4"				
	32	= 2"			24	= 1-1/2"				
	40	= 2-1/2"			32	= 2"				
	48	= 3"			40	= 2-1/2"				
	64	= 4"			48	= 3"				
					64	= 4"				

SPECIAL NOTE: Nominal hose & coupling sizes listed in 1/16"; i.e. 12 = 3/4", 6 = 3/8", etc.

ACCESSORIES

Rubber caps
TPDC



Rubber plugs
TPDP



Inexpensive method to protect your investment against contamination and damage. Comes with a loop to fit over pipe fitting or affixing to equipment with sheet metal screw. Available in sizes 1/4" through 1".

Aluminium dust caps
TADCH



Aluminium dust plugs
TAMPH



Alternate method to protect your equipment. Aluminium dust caps and plugs are available in sizes 1/4" through 3". 1/4" through 3/4" sizes come with 10" chrome plated brass bead chain. 1" and above come with steel zinc plated sash chain.

To order these accessories, use the basic part number and add the size using the suffix coupling size codes above. For example "TPDP6" to order a rubber dust cap 3/8".

Series N71

Flush Face/Dry Break Couplings

- **Flush Face/Dry Break** – Air inclusion and fluid loss are held to a minimum to prevent spillage and contamination of systems
- **Push-to-Connect** – Ideal on-hand operation when one half is mounted. Simply insert the nipple into the coupler and push-to-connect. To disconnect, retract the sleeve; and the coupling halves disconnect.
- **Rugged** – Heavy duty construction is ideally suited for high impulse applications.
- **Pressure Capability** – Designed for up to 3000 psi operating pressures.
- **Versatile** – Available in 316 stainless steel and other materials. Special seals for troublesome media are available; consult Thorburn for details.
- **Available sizes** – 1/4", 3/8", 1/2", 3/4", 1".
- **Superior flow and low pressure drop.**
- **Sleeve lock** – Designed to provide protection against accidental disconnection.

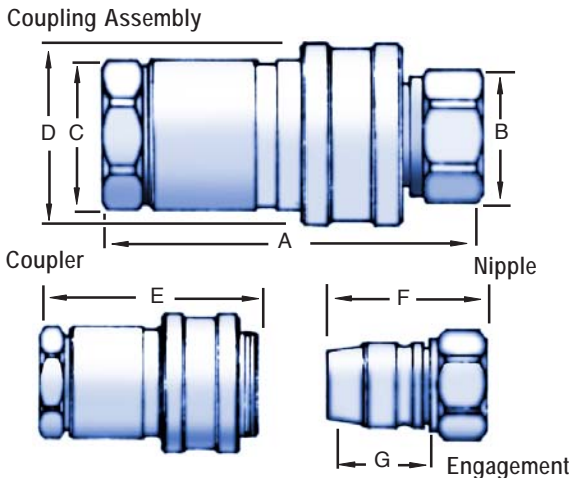
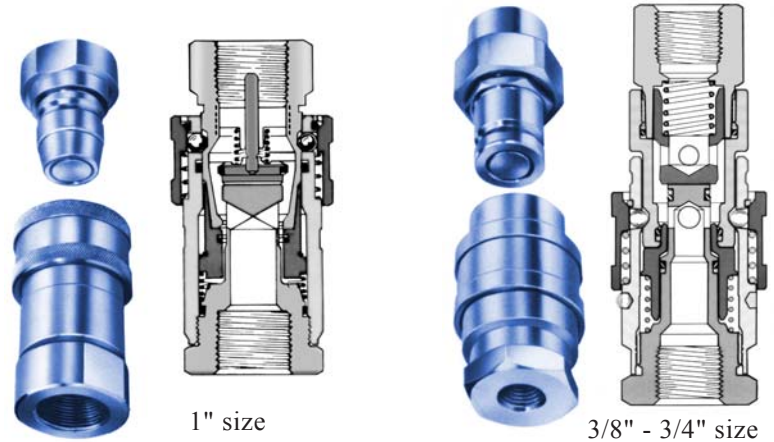

DIMENSIONS

Size	A	B(Hex)*	C(Hex)*	D(Dia.)	E	F	G
3/8"	4.11	1.00	1.19	1.56	2.55	2.49	.93
3/4"	5.06	1.75	1.75	2.25	3.35	2.96	1.25
1"	5.85	1.75	2.00	2.75	4.55	3.25	1.95

* Hex dimensions are taken from flat or hex and not across corners.

PRESSURE RATINGS, SPILLAGE, INCLUSION

Size (in.)	Spillage (cc)	Air Inclusion (cc)	Max. Working		Min. Burst*	
			psi	bar	psi	bar
3/8"	0.10	0.15	3000	207	12500	865
3/4"	0.10	0.40	3000	207	12500	865
1"	0.20	0.50	2500	172	10000	690

* Pressure ratings were established under static pressure conditions.

FLOW PRESSURE DROP

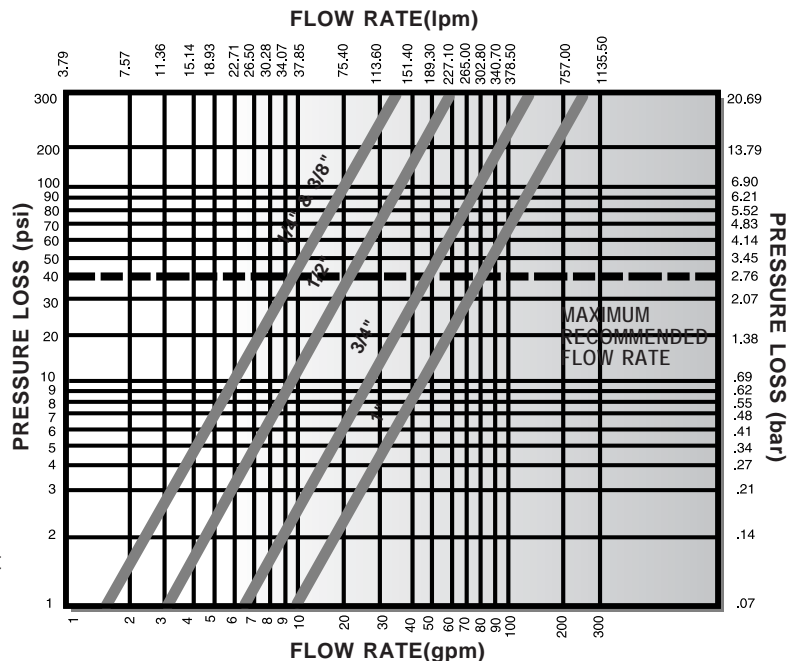

HOW TO ORDER THORBURN N71 SERIES

NS71	C	4-	F	B	SL
Series	Coupling	Coupling Half	End Fitting Size	Seals	Options Type
NS71	C	4 = 1/4"	F = Female NPTF	B = Buna	SL
Standard material	Coupler	6 = 3/8"	M = Male NPT	V = Viton	Sleeve
316SS	N	8 = 1/2"	T = Swage Lok compatible nut end ferrule 1/4" size only	E = EPDM	Lock
	Nipple	12 = 3/4"			
		16 = 1"			

* Available for 1/4" stainless steel units only.

SPECIAL NOTE: Nominal hose & coupling sizes listed in 1/16"; i.e. 12 = 3/4", 6 = 3/8", etc.

Series NT72

Double Shut-Off Valve Series Quick Coupling

- Designed to meet or exceed ISO 7241 Series B.
- Sizes 1/4" to 1".
- Proven ball-lock mechanism provides positive connections.
- Poppet style double shut-off.
- Sockets and plugs interchangeable with other manufacturers that conform to ISO 7241 Series B couplings.



Flow Capabilities

Series	C _V	C _V Less Valves	C _V With Valve Actuator	A _C	A _C Less Valves	C _V With Valve Actuator
NT72-04	1.1	2.2	1.0	1.1	55	1.0
NT72-06	1.9	4.0	1.8	48	100	45
NT72-08	3.2	7.6	3.1	80	190	78
NT72-12	8.2	21.0	8.2	205	525	205
NT72-16	11.4	36.0	11.5	285	900	288
NT72-20	16.9	69.9	24.5	422	1748	612
NT72-24	24.0	119.0	35.0	600	2980	875
NT72-32	50.0	232.0	76.0	1250	5800	1900

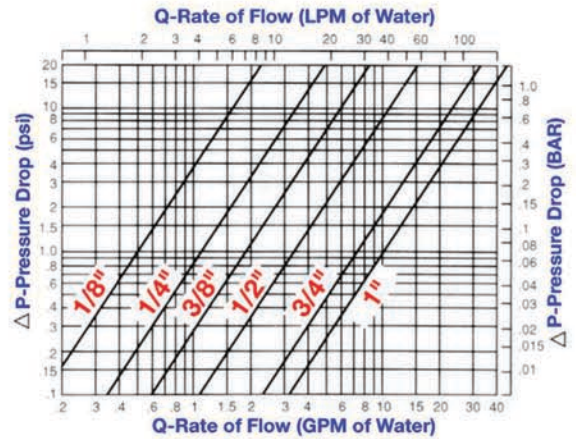

Dimensional Information

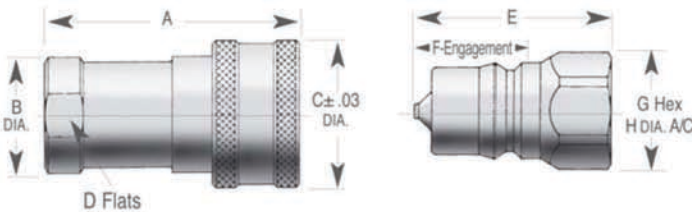

SIZE	A	B	C	D	E	F	G	H
1/4"	2.26	0.88	1.17	0.75	1.52	1.02	0.87	0.75
3/8"	2.56	1.00	1.42	1.00	1.76	1.24	1.01	0.88
1/2"	2.96	1.28	1.86	1.25	2.03	1.34	1.30	1.13
3/4"	3.48	1.56	2.22	1.50	2.36	1.79	1.52	1.31
1"	4.13	1.86	2.61	1.75	2.84	2.04	1.88	1.63

SIZE	A	B	C	E	G	H
1 1/4"	4.51	2.38	2.73	4.25	2.73	2.38
1 1/2"	4.82	2.38	3.23	4.76	3.02	2.38
2"	5.56	3.75	4.11	5.49	4.31	3.75

SIZE	PRESSURE RATING			
	BRASS		SS316	
	DESIGN	PROOF	DESIGN	PROOF
1/4	2000	9000	4200	18900
3/8	1500	6750	4200	18900
1/2	1500	6750	3500	15750
3/4	1500	6750	3500	15750
1	1000	4500	2200	9900
1 1/4	500	2250	1300	5850
1 1/2	500	2250	1300	5850
2	500	2250	1300	5850

How to Order

NT72	12	C	S6	FP	B	SL
TYPE	SIZE	COUPLING HALF	MATERIAL	END TYPE FITTING	SEAL	OPTIONS
NT72	04= 1/4" 06= 3/8" 08= 1/2" 12= 3/4" 16= 1" 20= 1 1/4" 24= 1 1/2" 32= 2"	C= Coupler N= Nipple DP= Dust Plug DC= Dust Cap	B= Brass S5= SS564 GR 630 S6= SS316	FP= Female NPT XX= Special End	V= Viton B= Buna N E= EPDM	SL= Sleeve Lock

Series NT82

Straight Through Series Quick Coupling

- Designed to meet or exceed ISO 7241 Series B.
- Sizes 1/4" to 2".
- Proven ball-lock mechanism provides positive connections.
- Sockets and plugs interchangeable with other manufacturers that conform to ISO 7241 Series B couplings such as Hansen ST Straight-Through Series
- Thorburn's NT82 series can be designed, manufactured and registered to ASME B31.1, and ASME Section III, class I, II or III services.
- Standard material - Brass (ASTM B16/B21)
Stainless Steel springs balls and retaining rings



Dimensional Information

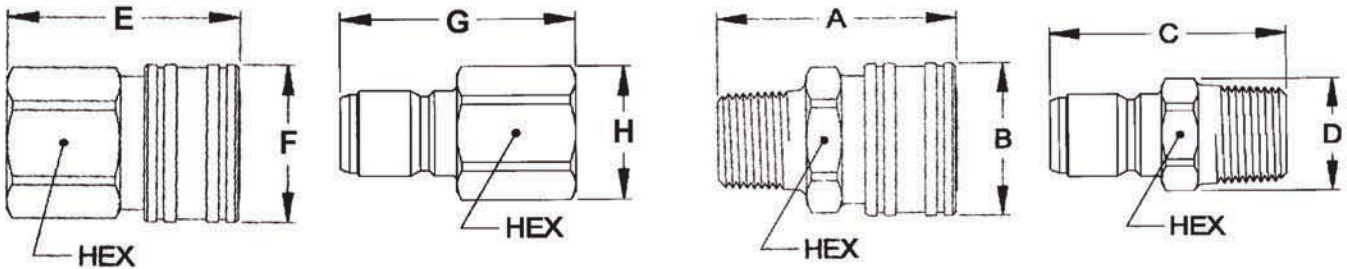

SIZE	COUPLER			PLUG				PRESSURE RATING (PSI)			
	A	B	H	MPT		FPT		BRASS		SS 316	
1/4	1.50	0.94	0.81	1.50	0.62	0.65	0.68	DESIGN	PROOF	DESIGN	PROOF
3/8	1.59	1.13	1.00	1.63	0.68	1.69	0.81	3700	16650	4000	18000
1/2	1.92	1.30	1.12	1.88	0.88	2.03	1	1950	8775	3500	15750
3/4	2.06	1.63	1.50	2.00	1.12	2.25	1.12	1600	7200	2000	9000
1	2.33	1.99	1.75	2.18	1.38	2.53	1.62	1250	5625	1250	5625
1 1/4	2.44	2.50	2.00	2.34	1.75	2.72	2	1000	4500	1000	4500
1 1/2	2.88	3.12	2.62	2.88	2.25	3.31	2.25	1000	4500	1000	4500
2	3.08	3.74	3.00	3.25	2.75	3.50	2.75	1000	4500	1000	4500

Note:
Proof pressures listed were taken at the point at which failure made the coupling inoperative. Burst pressure is 5 times design.

WARNING:
Over-pressurization could result in a sudden failure of the coupling, causing severe bodily injury or death. Be sure to select the proper coupling for your application and use it only within the specified service pressure range.

Flow Charts

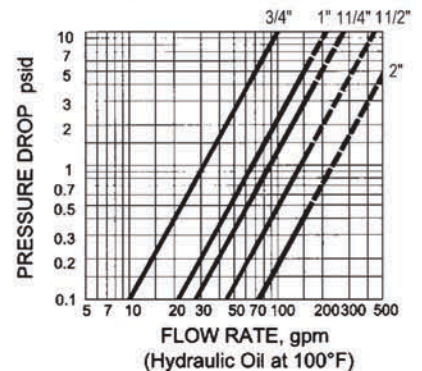
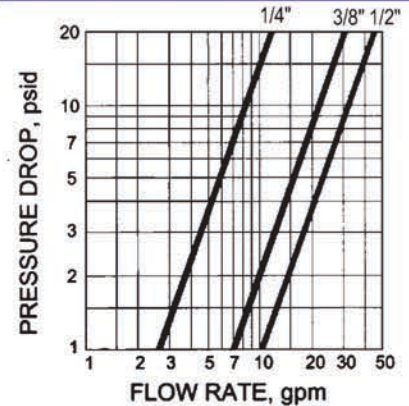

HOW TO ORDER

Type	Size	Coupling Half	Material	End Fitting Type	Seal	Options
NT82	06= 3/8" 08= 1/2" 12= 3/4" 16= 1"	C=Coupler N=Nipple DP=Dust Plug DC=Dust Cap	C=Carbon Steel B=Brass S4=Stainless Steel 304 S6=Stainless Steel 316	FP=Female NPT MP= Male NPT	V= Viton B=Buna N E=EPDM	SL=Sleeve Lock

Series NT803 Super Swivel Heavy Duty Hydraulic Rebuildable Swivels

- Available in sizes 1/4" through 2".
- Rated to 5000 psi working pressures.
- Thorough hardened.
- Made from Code Grade SA564
- Chrome ball bearings for long life.
- Larger ball bearings for more bearing area.
- Burnished barrel bores.

- Viton seals standard.
- Lower rotating torque.
- Withstands heavy loads.
- No snap ring to blow off.
- Rebuilding kits available.



Inline Super Swivel

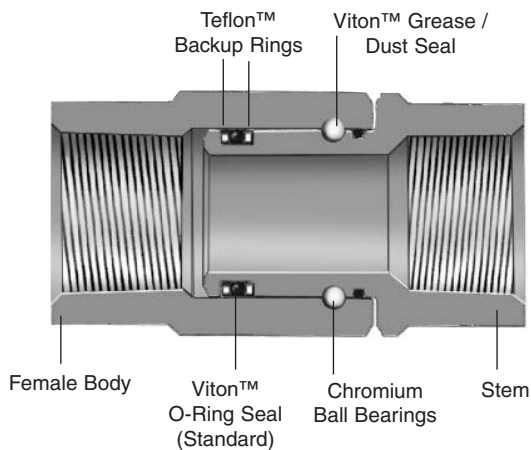

90° Super Swivel

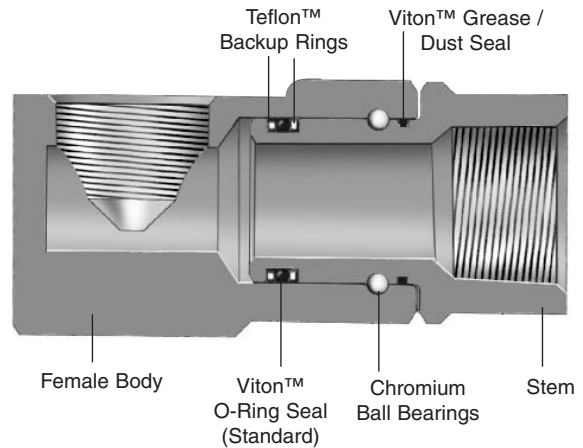

Dimensional Information

SIZE	A	B	TH'D T	TH'D T1	WRENCH FL.	DIA
1/4"	2.572	1.720	1/4-18	1/4-18	1	1.170
3/8"	2.835	1.850	3/8-18	3/8-18	1 1/4	1.420
1/2"	2.835	1.850	1/2-14	1/2-14	1 3/8	1.545
3/4"	2.835	1.850	3/4-14	3/4-14	1 5/8	1.795
1"	3.660	2.480	1-1/2	1-1/2	2.00	2.125
1 1/4"	4.025	2.685	1 1/4-11 1/2	1 1/4-11 1/2	2.375	2.500
1 1/2"	4.700	3.290	1 1/2-11 1/2	1 1/2-11 1/2	2.500	2.625
2"	5.200	3.800	2-11 1/2	2-11 1/2	3.00	3.250

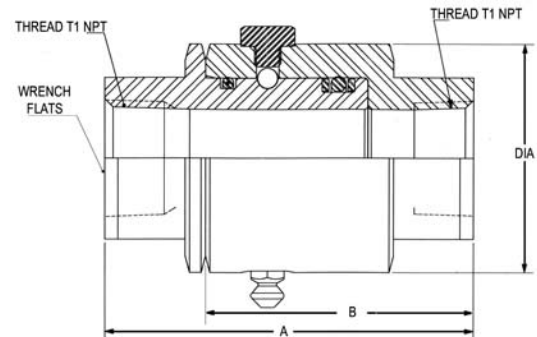

SIZE	PRESSURE RATING @ 21°C	
	DESIGN	PROOF
	SA564 SS GR.630	
1/4	4000	16000
3/8	4000	16000
1/2	4000	16000
3/4	3500	14000
1	3000	12000
1 1/4	3000	12000
1 1/2	2000	8000
2	2000	8000

How to Order

TYPE	SIZE	END TYPE T1 THREAD	END TYPE T2 THREAD	MATERIAL
NS803	04= 1/4"	04 = 1/4"	04 = 1/4 "	S5= SA564 Grade.630
	06= 3/8"			
	08= 1/2"			
	12= 3/4"			
	16= 1"			
	20= 1 1/4"			
	24= 1 1/2"			
	32= 2"			

Model NTFD69

High Pressure Water Blast Coupling 10,000 psi

Thorburn's Model NTFD69 design has a greater surface contact for long service life in high pressure applications. Thorburn's NTFD69 Series quick-disconnect water blast coupling permits quick and easy connection of hose assemblies to each other, to the pump and to the cleaning wand. Simply retracting the sleeve permits easy connection and disconnection.

To prevent accidental disconnection, the coupling features two (2) safety devices: 1) a sleeve guard and 2) a sleeve lock.

Each coupling is factory tested to 15,000 psi, tagged and serialized for your safety. Thorburn's TFD69 is registered to ASME B31.1 service at 10,000 psi. Available in corrosive resistant 316SS.

FEATURES

- Minimum burst pressure 40,000 psi
- Safety sleeve lock guards against accidental disconnection
- Smooth bore "straight through" design for high flow
- Heavy duty back-up ring to prevent O-Ring extrusion
- Made from corrosion resistant 316 stainless steel



NTFD69 nipple

NTFD69 coupler

TECHNICAL SPECIFICATIONS

Temperature range:	-40°F to 212°F
Design Pressure:	10,000 psi
Minimum Burst Pressure:	40,000 psi
Vacuum:	28 in/Hg
Rated Flow	45 US gpm
Gaskets	Buna N standard Also available in Viton and EPDM

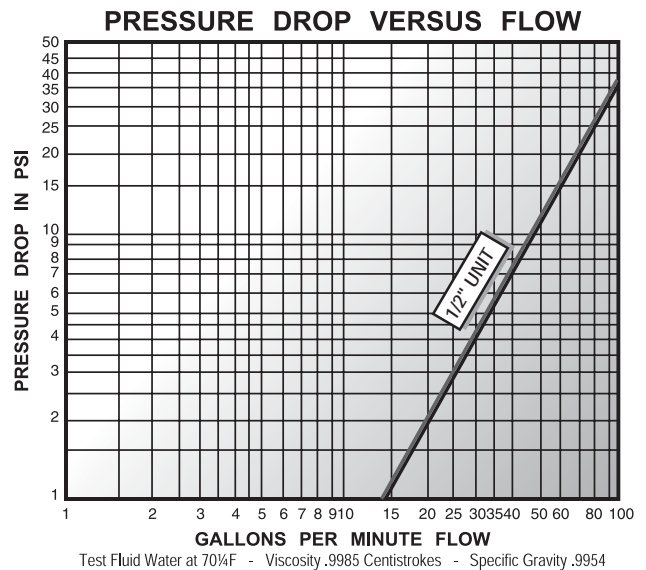

Female Pipe Coupler

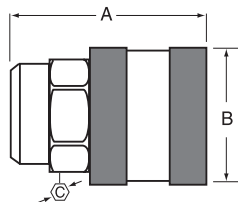

Female Pipe Nipple

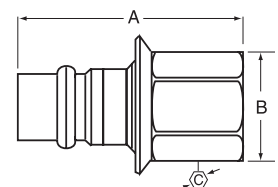

Thorburn Part #	Size (in.)	Female Pipe Thread (in.)	Dimensions (in.)		
			A	B	C
NTFD69C08S6	1/2	1/2 - 14	2.13	1.62	1.64

Thorburn Part #	Size (in.)	Female Pipe Thread (in.)	Dimensions (in.)		
			A	B	C
NTFD69N08S6	1/2	1/2 - 14	2.34	1.30	1.64

Series NT85 High Pressure Thread to Connect Couplings

Thorburn Series NT85 high pressure couplings have superior pressure and flow characteristics and are designed for rugged hydrostatic drive applications.

NT85 DESIGN FEATURES

- **Excellent flow characteristics** for continuous duty application. See flow chart.
- **High strength steel poppet** guides prevent breakup and washout of coupling valving during high surge and shock conditions.
- **Exclusive four point support design of poppet guide** provides positive alignment of valving during high surging flow conditions.
- **Flat crested stub-acme threads and all steel construction** withstand storage and rig-up damage.
- **Protective treatment** equal to industry standards for SAE steel hose fittings.
- **Structurally compatible** with weight of 3,000 psi flex-hose and system induced shockloads.



Pressure Drop vs. Flow (USGPM) - Coupling

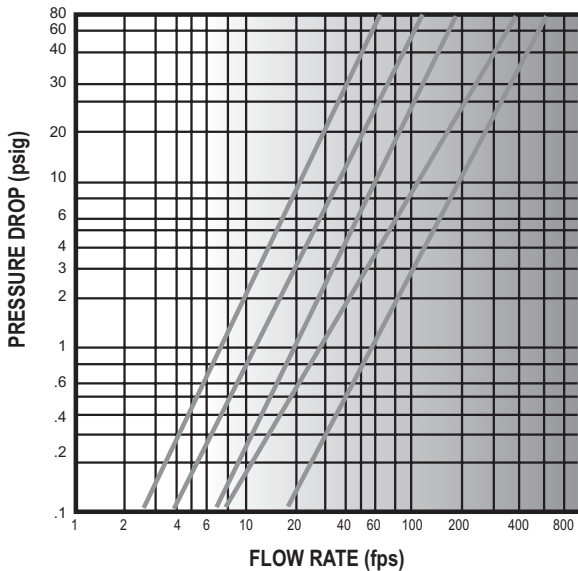

OPERATING LIMITS

- **3,000 psi operating pressure**– all sizes
- **20,000 psi minimum burst**– coupled
- **Vacuum to 28" Hg**
- **Standard seal**– temperature range -65°F to +250°F
- **Buna-N seals**– standard

PRESSURE RATINGS

Size	Spillage (CC)	Air Inclusion (CC)	Max Design Pr		Min Burst Pr	
			PSI	BAR	PSI	BAR
3/4"	8	12	4,000	276	20,000	1379
1"	16	25	4,000	276	20,000	1379
1-1/4"	31	48	3,000	207	15,000	1035
1-1/2"	64	98	3,000	207	15,000	1035
2"	141	205	3,000	207	15,000	1035

HOW TO ORDER

Size	Materials	Coupling Half	Coupling Size	End Fitting	Seals
NT85	Standard material carbon steel C= Carbon steel S6=316SS	C=Coupler N=Nipple DP=Dust Plug DC=Dust Cap	12=3/4" 16=1" 24=1 1/2" 32=2"	Standard is FP FP= Female NPTF MP=Male NPT MJ=Male 37° FL= Code 61 Flange	B= Buna V= Viton* E= EPDM *Trademark of Dupont

Special Note: Nominal hose & coupling sizes listed in 1/16"; i.e. 12 = 3/4", 6 = 3/8", etc.

Dimensional Information

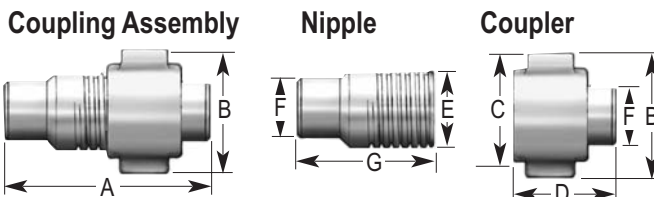

Size	A	B	C (Dia)	D	E (Dia.)	F	G	Acme H
3/4"	4.85	-	1.87	2.84	1.75	1.35	3.27	1 3/4" - 8
1"	6.04	4.25	2.75	3.45	2.25	1.77	4.17	2 1/4" - 6
1-1/4"	7.76	4.75	3.25	4.40	2.62	2.14	5.36	2 5/8" - 6
1-1/2"	8.70	5.75	3.75	5.04	3.24	2.50	5.97	3 1/4" - 4
2"	10.05	6.75	4.75	6.07	4.00	3.25	7.05	4" - 4

Aluminium dust caps THA-DC Sizes 1/4" to 1"	Aluminium dust plugs THA-DP Sizes 1/4" to 1"	Plastic caps THP-DC Sizes 1/4" to 2"	Plastic plugs THP-DP Sizes 1/4" to 2"
--	---	---	--

Model NT92 Omega™ Dry Break Ball Valve Style Quick Coupling

NT92 Series Omega™ Dry Break Quick Coupling was specifically designed to prevent radioactive resin valve blockage spillage during the disconnecting process. This unique coupling consist of a female end having a concave ball valve and a male end having a convex ball valve that are machined to eliminate any spaces between the ball valves. Added to the design is a cavity filler and a revolutionary Omega™ Sealing Process. The seal is in tension not compressed yielding a superior seal with greater strength and longer cycle life. Thorburn's Omega™ coupling provides the solution to resin blocking poppet type valve quick couplings which spill radio active materials.



Designed for ASME Section III Applications
From Full Vacuum to 500 PSI

Omega™ Sealing Technology Seals Under Temperature & Pressure Fluctuations

Omega™ Seals flattens the seat creating tension and tensile strength in the seat center of the valve body during assembly. This guarantees sealing under vacuum or low pressures and temperature fluctuations.

Shock Absorbing Cavity Fillers
Prevents resin blockage

High Radiation Resistant Seals
UHMWPE: 10⁵ and PEEK: 10⁹

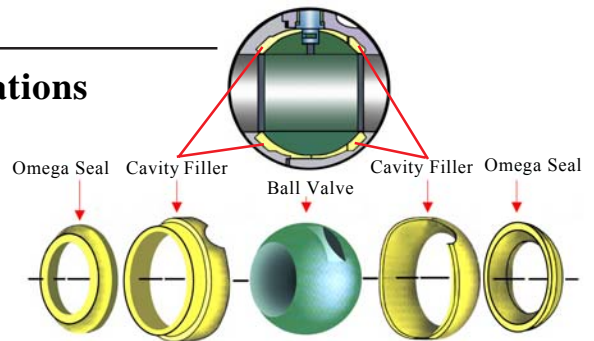

Omega™ Dry Break Coupling Outstanding Features



- **Zero spillage during disconnection**
Eliminates hazardous chemical waist pollution.
- **No accumulation of D2O resins or other solids suspended in the media**
Prevents resin blockage between the valves.
- **Built in Swivel**
Eases alignment regardless of hose orientation
- **Unrestricted high flow during operation**
Reduces pressure drops.

Thorburn's Omega™ is a "Drip Free" hose coupling that minimizes exposure to fluids or vapours during fluid transfer. The full flow smooth bore design means better flow for highly viscous fluids. A quarter turn of the ball valve securely seals the process fluids within the line. The unique locking mechanism prevents accidental disconnects. The standard swivel end eases alignment regardless of hose orientation.

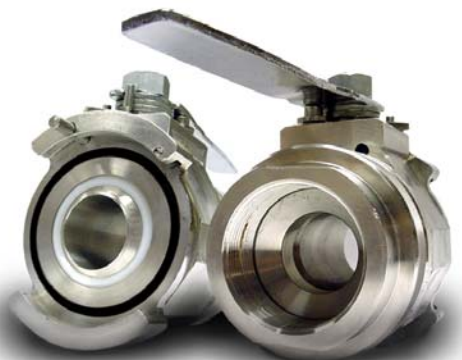

Eliminate Spillage with Omega™ Couplings

You should use Omega™ dry break quick couplings if your product is hazardous, corrosive, flammable, caustic, toxic or expensive...

Cam and Groove Type Couplings
No Valve = Spillage



Cam and Groove type couplings are incapable of avoiding spillage and vapour leakage upon disconnection. They are prone to accidental disconnects which can be expensive and extremely hazardous.

Ordinary Ball Valves added = Spillage



Ordinary Ball Valves added to quick couplings to shut off the flow allow trapped liquid between the hose and the adapter to flow freely on to your plant's floor or your employees hands upon disconnection.



Traditional Poppet Valve = Spillage



Traditional two-way poppet valve style dry break couplings by its very design are predisposed to spills because of the unavoidable liquid that is trapped in the gap between the coupler poppet valve and the adapter poppet valve upon disconnection.

No Leaks & No Spills with Omega™ Couplings



Omega™ prevents resin valve blockage spillage

- Ideal for use where spillage may cause undesirable conditions
- Protects the installation assets from hazardous waste product
- Eliminates chemical waste incineration and disposal costs
- Reduces liability exposure, loss time and worker comp claims
- Ideal for high purity chemicals transferred through hoses



No Leaks

No Spills



Omega™ Couplings eliminate spillage of residual liquid trapped in the line after disconnection. Therefore, protecting the environment and meeting strict worker safety regulations and environmental protection laws.

How to Operate the Omega™ Quick Coupling

Easy operation to start the product flow

Engineered to be user friendly, The Omega™ coupling has an easy turn action to connect and start the product flow. The valves will not open until the coupling halves are connected properly. The coupling halves are first aligned and then connected with a push, followed by a quarter turn. There are no threads to damage by over tightening and no failure prone cam and groove latch connections to secure. The coupling halves are independent shut off ball valves that are controlled manually by rotating the valve handles in sequence providing unrestricted high flow in either direction.



Align coupling halves

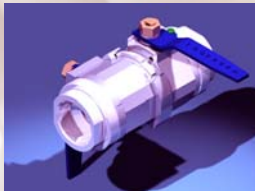

Push together & turn 90°

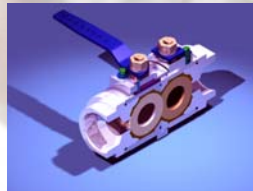

Connected & locked

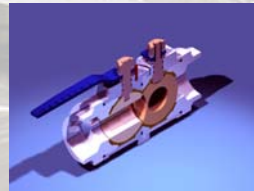

Open male end valve



Open female end valve

The Omega™ can only be disconnected when the valves are shut off in sequence; female end valve first and male end valve second. This ensures zero spillage and protects against accidental disconnection.

Omega™ Coupling Operational Safety Features

The Omega™ has built in safety features which requires a deliberate sequential procedure by users during operation.



Convex/concave ball valves



Safety locking mechanism



Valve handle safety switch



Safety locking pin



Safety locking pin slot

- 1- Convex (male end)/Concave (female end) Ball Valve Zero Gap System prevents hazardous chemical loss when the coupling is disconnected.
- 2- Safety Locking Mechanism incorporates a Valve Handle Safety Button and a Safety Locking Pin prevents accidental openings.
- 3- Valve Handle Safety Button locks the handle in the off position to safeguard against accidental opening when the coupling is disconnected. The user must push down the Valve Handle Safety Switch to turn the valve handle to the on position.
- 4- Valve Handle guides a Locking Pin on the male end coupler into the Locking Pin Slot on the female end coupler
- 5- Locking Pin Slot on the female end coupler locks the two coupling halves together and protects against accidental disconnection during operation.

NT92 Technical Data

Design Pressure: 500 PSI

(For all sizes 1/4" to 3")

Warning: Thorburn's Omega™ coupling does not eliminate possible exposure to hazardous residue which may appear on both coupling disc faces. The conditions of handling and use are beyond Thorburn's control. We make no guarantee and assume no liability for damages or injuries related to the use of this coupling. It is the responsibility of the user to comply with all applicable federal, state and local laws and regulations. Always employ safety precautions and handling techniques. Failure to do so may result in serious personal injury, property damage or leakage.

How to Order

NT92 Type	S6 Material	C Coupling Half	12 Size	FP End Type Fitting	V Seal	SL Option
NT92	S6-SS316	C - Coupler N - Nipple DP - Dust Plug DC - Dust Cap	04 - 1/4" 06 - 3/8" 08 - 1/2" 12 - 3/4" 16 - 1" 20 - 1 1/4" 24 - 1 1/2" 32 - 2"	FP - Female NPT XX - Special End	V - Viton	YY - Specify

Hose Assembly Instructions

Cutting the hose

1. To determine the "J" length (cut length of hose) from "OA" (overall length) deduct "D" dimensions of both end fittings. Consult reusable fitting information pages for "D" dimensions. For hose assemblies with Push-on and Lock-in hose fittings, add 1/2' to "J" length. Tip: If the old Thorburn assembly was the right length, simply remove the hose fittings and measure the hose.
2. Cut the hose square. Use a cutoff wheel or a fine-tooth hacksaw.

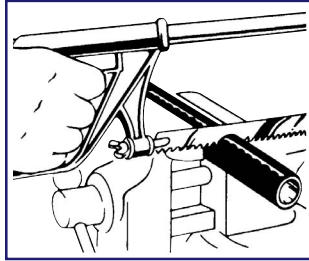

3. Clean the hose bore. Blow out shavings with shop air or flush with a solvent compatible with the hose construction. Caution: Follow proper safety procedures.

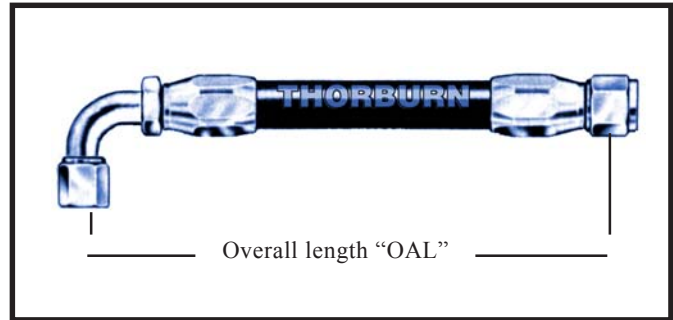
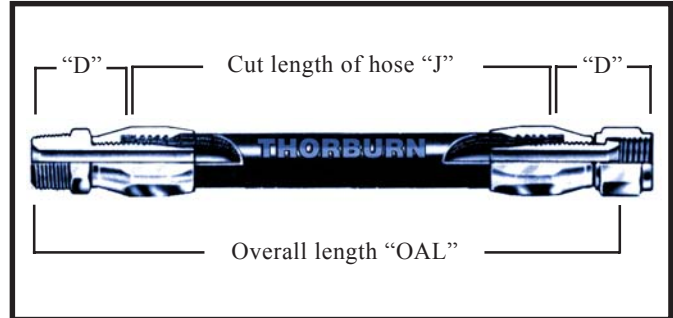
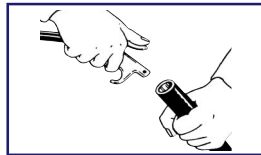

ASSEMBLY TIPS

Assembly terms

- **Skive Strip**, as to strip-off a thin cover of material
- **Dash size** The hose or fitting size expressed in 1/16ths of an inch.
The numerator of a fraction whose denominator is 16.
Example:
-8- or 08 is $8/16" = 1/2"$.
- **Nipple** The part of a hose fitting that goes into the hose tube.
- **Socket** The part of a hose fitting that goes over the hose cover or reinforcement.
- **Mandrel** A round, properly sized, steel bar used for support during assembly of the fitting or skiving the hose cover.
- **Annular** A groove that is not helical like a screw thread.

REUSABLE FITTING TIPS TO REMEMBER FOR EASY ASSEMBLY

- Part numbers and dash sizes are indicated on fitting sockets.
- It is essential the fitting be mated with a compatible hose style with the same dash size.
- Reusable fittings that have a notch in the socket serve as a reference for the cover skiving length.
- Familiarize yourself with the assembly instructions before you start to make an assembly.
- For hoses that require skiving, be sure to skive the hose to the proper length and down to the wire reinforcement.
- Use Murphy's oil soap liberally on both the inside of the hose and on the fitting nipple.
- Always cut hose square by using a sharp instrument (hacksaw or cutoff wheel).
- For volume production of hose assemblies use Thorburn Assembly Equipment.

PHASE ANGLE (OFFSET)

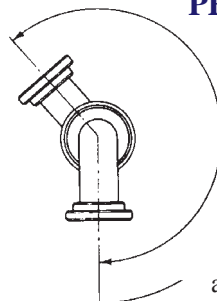

When making double elbow assemblies, the following steps should be followed to obtain the desired angle between elbows. Tighten both elbows to maximum allowable gap between socket and nipple hex. Start to position for relative angle between elbows. Finish assembly by adjusting both elbows. Backing off to get desired angle should be avoided.

Field Assembling Instructions

Standard NC2AEH, NC2ATH Style

Step 1

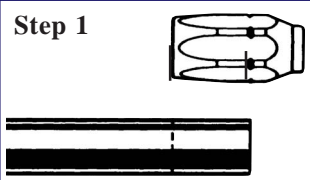

Cut the hose to length required using a cutoff wheel or a fine-tooth hacksaw. Clean the hose bore.

Hose must be stripped of its rubber cover before inserting in socket. Locate skiving point by putting hose end next to socket as shown. Measure from hose end of socket to notch on socket.

Step 1A

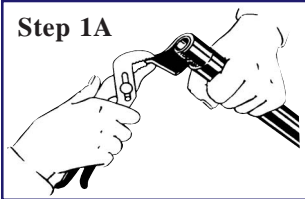

Skive Hose: By Hand: Cut rubber cover around down to wire reinforcement. Slit lengthwise. Raise flap and pull off with pliers. Clean excess rubber off wire reinforcement with wire brush or soft wire wheel. Do not fray or flare wire reinforcement when brushing.

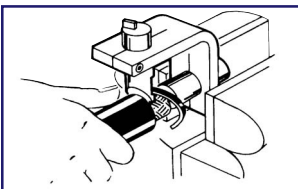

Skive Tool: Use the correct size Thorburn TH1229 hose cover skiving tool. Mount the tool in a vise. Push the hose over the mandrel. Rotate the hose clockwise until it bottoms or secure hose in a vise and attach TH1279 auger to the skive tool. Insert mandrel into the hose and rotate clockwise until it bottoms.

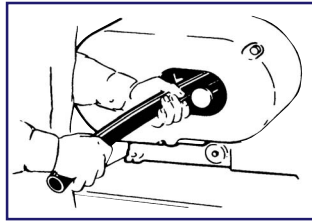

Machine: Use the Thorburn cut-off and skiving machine. Consult the owners manual. Select the correct mandrel. Turn on the machine. Put the hose over the mandrel and rotate.

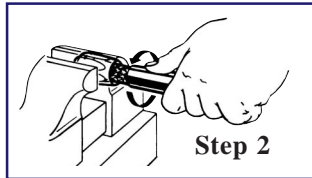

Put socket in vise. Screw hose into socket counterclockwise until it bottoms. When assembling long lengths of hose, it may be preferred to put hose in vise just tight enough to prevent from turning, and screw socket onto the hose counterclockwise until it bottoms.

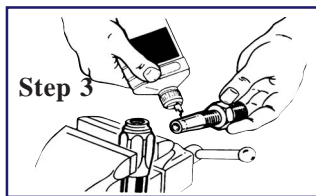

Lubricate nipple threads and inside of hose liberally. Use Murphy's oil soap.

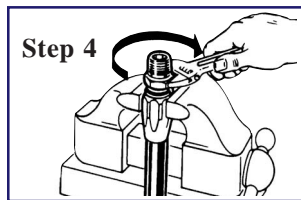

Screw nipple clockwise into socket and hose. Leave 1/32" to 1/16" clearance between nipple hex and socket. Recommendations for cleaning, inspection and testing are summarized on page 26. Disassemble in reverse order.

Thru-the-cover NC5R style reusable fittings

Step 1

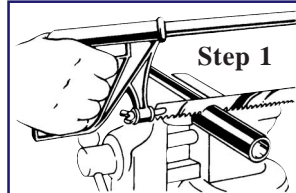

Cut the hose to length required using a cutoff wheel or a fine-tooth hacksaw. Clean the hose bore.

Step 2

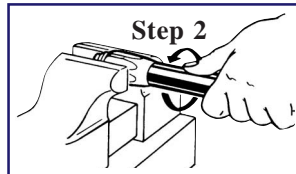

Liberally lubricate hose cover with Murphy's oil soap. Place socket in vise and hose into socket counterclockwise until it bottoms. When assembling long lengths of hose, it may be preferred to put hose in vise just tight enough to prevent from turning, and screw socket onto the hose counterclockwise until it bottoms.

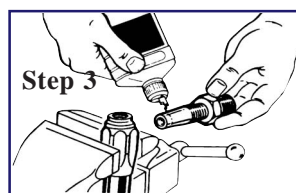

Lubricate nipple threads and inside of hose liberally. Use Murphy's oil soap.

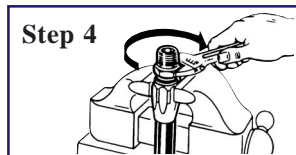

Screw nipple clockwise into socket and hose. Leave 1/32" to 1/16" clearance between nipple hex and socket. Recommendations for cleaning, inspection and testing are summarized on page 26. Disassemble in reverse order.

Push-on Lock-in fittings with textile braid low pressure NLOL hose

To Assemble

Step 1

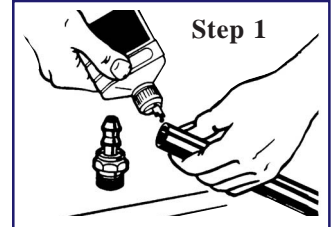

Cut the hose to length required with a sharp knife. Put Murphy's oil soap inside of hose and outside of nipple LIBERALLY

Step 2

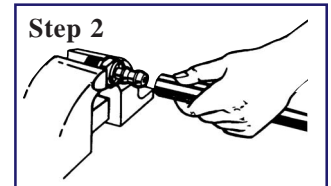

Push hose on fitting until hose bottoms underneath protective cap as shown. For quantity production use a Thorburn Push-on Lock-in Fitting assembly machine.

To Disassemble

Step 3

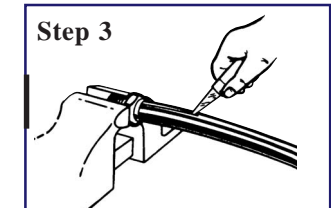

Slit hose lengthwise from protective cap to end of nipple.

Step 4

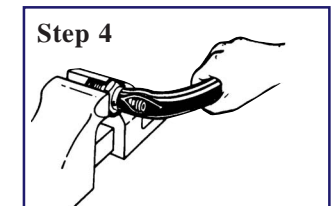

Bend hose, then snap hose off with a quick tug.

Service Life Factors

Thorburn hose assemblies like other products, have a finite service life. The actual service life of a given hose assembly in a given application is dependent on many variables, including those below.

1. Operating pressure

Thorburn hose lines are rated for continuous operation at the maximum operating pressure specified for the hose. Generally, the operating pressure is one fourth the hose minimum burst pressure.

2 Pressure surges

Exposing the hose to surge pressure above the maximum operating pressure will shorten hose life and must be considered. In systems where surges are severe, select a hose with a higher maximum operating pressure.

3. Burst pressure

These are test values only and apply to hose assemblies that have not been used for less than 30 days.

4. High pressure

High pressure gaseous systems especially over 250 psi are very hazardous and should be adequately protected from external shock and mechanical or chemical damage. They should also be suitably protected to prevent whip-lash action in the event of failure.

5. Operating temperatures

Operating temperatures specified refer to the maximum temperature of the fluid or gas being conveyed. High heat conditions may have an adverse effect on hoses due to degradation of the rubber which will limit hose usefulness and reduce fitting retention. In some cases the fluid being conveyed will slow down this degradation whereas other fluids may accelerate it. Therefore, the maximum temperature of each hose does not apply to all fluids or gases. Continuous use at maximum temperatures together with maximum pressure should always be avoided. Continuous use at near the maximum temperature rating will cause a deterioration of physical properties of the tube and cover of most hoses. This deterioration will reduce the service life of the hose.

6. Ambient temperatures

Very high or low (outside of hose) ambient temperatures will affect cover and reinforcement materials, thus reducing the life of the hose.

7. Bend radius

Recommended minimum bend radii are based on maximum operating pressures with no flexing of the hose. safe operating pressure decreases when bend radius is reduced below the recommended minimum. Flexing the hose to less than the specified minimum bend radius will reduce hose life.

8. Chemical resistance

Consider the chemical resistance of the fitting, O-Ring, hose cover and tube stock when using Thorburn hose assemblies.

9. NLOL Hose

Thorburn NLOL hose is not recommended for impulsive hydraulic applications.

10. Hose fittings

Thorburn manufactures hose fittings to meet applicable SAE ASME, N285.0 standards. It is possible to select a fitting with a connecting end that has a performance rating lower than the hose rating. In selecting hose fittings, please consider the performance rating of the connecting end.

IMPORTANT -
Hose assembly inspection

Hose assemblies in service should be inspected frequently for leakage, kinking, corrosion, abrasion, or any other signs of wear or damage. Hose assemblies that are worn or damaged should be removed from service and replaced immediately.

Cleaning, inspection, testing and storage of hose assemblies

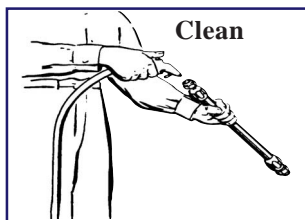

Maintenance

Hose assemblies in operation should be inspected frequently for leakage, kinking, abrasion, corrosion or any other signs of wear or damage. Worn or damaged hose assemblies should be replaced immediately.

Clean

Clean assembly by blowing out with clean compressed air. Assemblies may be rinsed out with mineral spirits if the tube stock is compatible with oil. Otherwise hot water at 150°F. max. may be used. Consult Thorburn for special cleaning equipment.

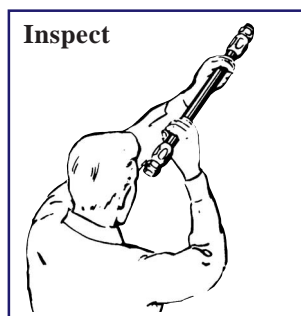

Inspect

Examine hose assembly internally with a boroscope or flashlight for cut or bulged tube, obstructions, and cleanliness. Check for proper gap between nut and socket or hex and socket. Nuts should swivel freely. Check the layline of the hose to be sure that the assembly is not twisted. Cap the ends of the hose with plastic covers to keep clean.

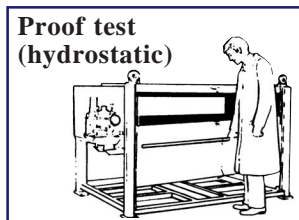

Proof test (hydrostatic)

The hose assembly should be hydrostatically tested at twice the recommended working pressure of the hose.

Test pressure should be held for not more than one minute and not less than 30 seconds. When test pressure is reached, visually inspect hose assembly for: a) any leaks or signs of weakness; b) any movement of the hose fitting in relation to the hose. Any of these defects are cause for rejection.

Caution: testing should be conducted in approved test stands with adequate guards to protect the operator.

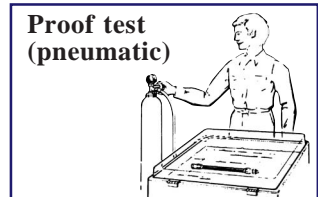

Proof test (pneumatic)

Hose assemblies intended for gas or air service should be tested with air or nitrogen at 100 psi with the assembly immersed in water. Random bubbles may appear over the hose and fitting area when assembly is first pressurized. This should not be construed as a defect. However, if the bubbles persist in forming at a steady rate at any particular point on the hose, the assembly should be rejected.

Caution: testing should be conducted in approved test stands with adequate guards to protect the operator.

Storage and handling

Hose should be stored in a dark, dry atmosphere away from electrical equipment, and the temperature should not exceed 90°F. Storage in the original shipping container is preferred.

LOL; N5CR; NC2AH; NC2AEH with Reuseable End Fittings



Hose Size	Hose Type	1st End		2nd End		O.A.L. inches	Nuclear Class 1, 2, 3
		Size & Type	Material	Size & Type	Material		
N12	C2AEH	12RMB	6C	12RFJX	6C	480	Class 3

Special note:
For Class 6; B31.1; B31.3
leave Class Code blank

End Material Codes		
Material	ASME	Codes
Brass	B21/B16	B
SS304 ⁽¹⁾	SA479	S4
SS316 ⁽¹⁾	SA479	S6
SS316/Steel	SA479/A108 ⁽³⁾	6C ⁽²⁾
Carbon Steel / Nickel plated	A108 ⁽³⁾	CN ⁽⁵⁾
—	—	NP ⁽⁴⁾

ASSEMBLY DESCRIPTION

3/4" hose type N12C2AEH c/w 3/4" Sure-Grip reusable male "O" ring boss coupling nipple in 316SS and socket in nickel plated steel, other end 3/4" Sure-Grip reusable female 37° (JIC swivel) coupling nipple in 316SS and socket in nickel plated steel 480" long Code Class 3.

Notes

- (1) All standard parts in stainless steel (304 or 316); insert threads plated with silver. (No Plating, put suffix "NP" after S4, S6, i.e. S4NP, S6NP)
- (2) Wetted parts (nipple) 316SS. Non-wetted parts (socket) carbon steel nickel plated.
- (3) Other carbon steel materials i.e. SA695, SA696, SA739.
- (4) Material not plated, add NP as suffix to Codes S4 and S6; i.e. S4NP, S6NP)
- (5) Carbon Steel/ Nickel Plated

Hose & Coupling	
Size	Codes
1/4	= 4
3/8	= 6
1/2	= 8
3/4	= 12
1	= 16
1 1/4	= 20
1 1/2	= 24
2	= 32
3	= 48

Hose Type Codes	
N*LOL	- Low Pressure
N*C5R	- Medium Pressure
N*C2AH	- High Pressure
N*C2AEH	- High Pressure

*= Insert size in 1/16"
(See Size Codes this page)
The prefix N = ASME certified product

Hose Coupling Type Codes	
**RFT	- Reusable Tube End
**RFTA	- Tube End Assembly
**RMP	- Reusable Male Pipe
**RMPU	- Reusable Male Pipe (not shown in this catalogue)
**RFJX	- Reusable Female Swivel 37°
**RMJ	- Reusable Male 37° Flared
**RMB	- Reusable "O" Ring Boss
**RFJX 90S	- Reusable 37° Female Swivel 90° Short Stem
**RFJX 90L	- Reusable 37° Female Swivel 90° Long Stem
**RFFX	- Reusable Flat Face "O" Ring Swivel

**For metric or special ends, contact Thorburn

WARNING This catalogue is the exclusive proprietary property of THORBURN EQUIPMENT. It is issued with the understanding it will be retained in confidence and will neither be duplicated nor copied in whole or in part nor used for any purpose other than that for which disclosed. Therefore, reprinting of this catalogue for competitive use in whole or in part is strictly prohibited.